



Follow us on Facebook



ISO14001:2015

Follow us on YouTube



ISO9001:2015

Follow us on WeChat



Download "Hangcha Forklift" App



HANGCHA trucks conform to the European Safety Requirements.

2023 VERSION 3/COPYRIGHT 2023/04

HANGCHA GROUP CO., LTD. reserves the right to make any changes without notice concerning colors, equipment, or specifications detailed in this brochure, or to discontinue individual models. The colors of trucks, delivered may differ slightly from those in brochures.



X Series Electric Forklift Truck

with capacities of 1,000 to 3,500kg

The World of Hangcha



X Series Electric Forklift Truck

The X series 1.0- to 3.5-ton forklift trucks are new-generation products by independent research and development based on former products of HANGCHA, with an overall upgrade in appearance molding, performance efficiency, comfort, safety and maintainability.



Agile/
Efficient/
Flexible



Appearance

- / Appearance design methods of new concepts, streamlined surface modeling, flexible and smooth lines, elegant and decent.
- / Compact truck shape, simplified appearance, vigorous and powerful.
- / Optimum energy efficiency.

Stability

- / The traction motors are arranged in parallel, the batteries are fixed at the bottom of the truck frame, and the shaft distance and real-wheel distance have been lengthened, aiming to enhance the swing point of steering axle and shorten front overhang distance for excellent stability.

Efficiency

- / The inner and outer turning angle of steering wheels are enlarged with small turning radius, which can operate in narrow paths.
- / Multi-speed models for selection to adapt various working conditions.
- / A high-power traction motor and high-speed-ratio gearbox have been adopted. The maximum travelling speed and climbing gradient under full load have been increased to 16.5km/h and 20% respectively.
- / High-power pump motor with quiet and large discharge capacity has been adopted to promote lifting speed. For instance, the maximum lifting speed with 1.5-ton full load can reach 420mm/s.
- / Thanks to the stability technologies, such as new mast with shorter load distance, making a great promotion of loading capability and high lifting mast.
- / Compact design, the width of 2- to 2.5-ton truck is only 1180mm.
- / Light weight and low energy consumption. Brake energy regeneration system effectively saves energy and prolongs operation hours for one charge.

Comfort

- / Designed based on ergonomics, the longer wheelbase provides larger space for legs. The diameter of steering wheel has been decreased to 300mm. Seats can be adjusted forward and backward for operators to choose the best driving position.
- / Humanized design. Storing space, USB interface and others have been added.



New designed mast and the large open steel roof provide super visibility, it also can reduce risk of accidents



Fully closed operation plate space, tilting cylinder and flat bottom plate, providing more comfortable and safe operation



Side roll out the battery can provides the fast, simple and safe solution for the operator



Multi-function instrument with color screen, clear human-computer interaction interface for visualized reading



Standard specification

- / 3M duplex mast
- / Soft landing system
- / OHG
- / Storage compartment
- / Emergency power-off switch
- / USB interface
- / Full AC motor and controller
- / Multi-function color screen combination instrument
- / 2nd valve
- / Dynamic load sensing hydraulic steering gear
- / Panoramic rearview mirror
- / Integrated combination switch
- / DC-DC converter
- / LED front light, turning indicator light, LED rear combination tricolor light
- / Traction pin
- / Back-up beeper

Safety

- / LED front lights and combined lights provide better view to operators under any circumstance.
- / The panoramic rearview mirror provides broader rearview for safer driving.
- / Soft landing system: When forks are 100-60mm above the ground, the descending speed decreases automatically, keeping the goods and pallet from hitting the ground and protecting both goods and the ground effectively.
- / Overload protection device for electronics and hydraulics, conforming to safety specifications.

Maintenance

- / The bottom plate under feet can be disassembled without tools, which is convenient to check and repair all walking motors and systems.
- / Brake fluid can be added when the shield cover and oiler cover are opened.
- / Fully opening covers are quite convenient for the maintenance motors and controllers.

Advancement

- / High frequency MOSFET controller provides accurate control of travelling, lifting, and better adjustable performance, and better matches the motor. Regenerative braking, reverse current braking and anti-slide on slope function guarantee the operation safety.
- / AC controllers realize computer control in travelling, turning, lifting, inclining and other movements.
- / Regenerative braking is more energy saving and efficiency during truck's deceleration, direction changing, and driving on downwards slope.



Options

- / 2.0-5.0m duplex mast
- / 2.5-4.0m full free duplex mast
- / 4.3-7.0m full free triplex mast
- / Other length forks
- / Wide fork carriage
- / Wide or higher load backrest
- / Built-in side shifter
- / Accessories of other specifications
- / Front dual tire
- / Super-elastic solid tire
- / Non-marking tyre
- / Suspension seat with armrests
- / Suspension seat with higher OHG
- / Reversing hand grip with horn button
- / Left-right rearview mirror
- / Rear working light
- / Alarm light
- / Battery side removed by forks
- / Battery side roll out by roller
- / High-capacity domestic battery
- / High-performance imported battery
- / Maintenance-free battery
- / Lithium battery
- / Charger
- / OPS system
- / Fingertip system
- / 3T brake for 2-2.5t truck
- / Electric Parking Brake
- / KDS Motor

Lead-acid specification

Battery	Capacity (Ah/5h)	1.0t	1.5-1.75t	mini2t	2.0t	2.5t	2.5Lt	3.0-3.5t
Lead-acid	360	●					●	
	420		●					
	450			●				
	480	○	○				○	●
	525				●			
	560	○	○	○	○		○	○
	600			○	○	●	○	○
700				○	○			

Note: ● Battery Std. ○ Battery Opt. 2.5Lt:80V

Lithium specification

Battery	Capacity (Ah/5h)	1.0t	1.5-mini2t	2.0-2.5t	2.5Lt	3.0-3.5t
Lithium	302	●			●	
	456	○	●		○	●
	500			●		
	604		○	○	○	○

Note: ● Battery Std. ○ Battery Opt. 2.5Lt:80V



Fingertip system (Opt.)



Lithium battery (Opt.)

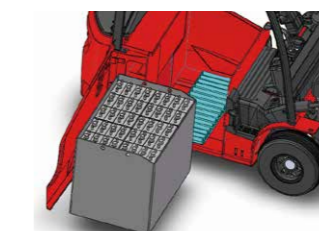

Battery side roll out by roller (Opt.)



Battery side removed by forks (Opt.)

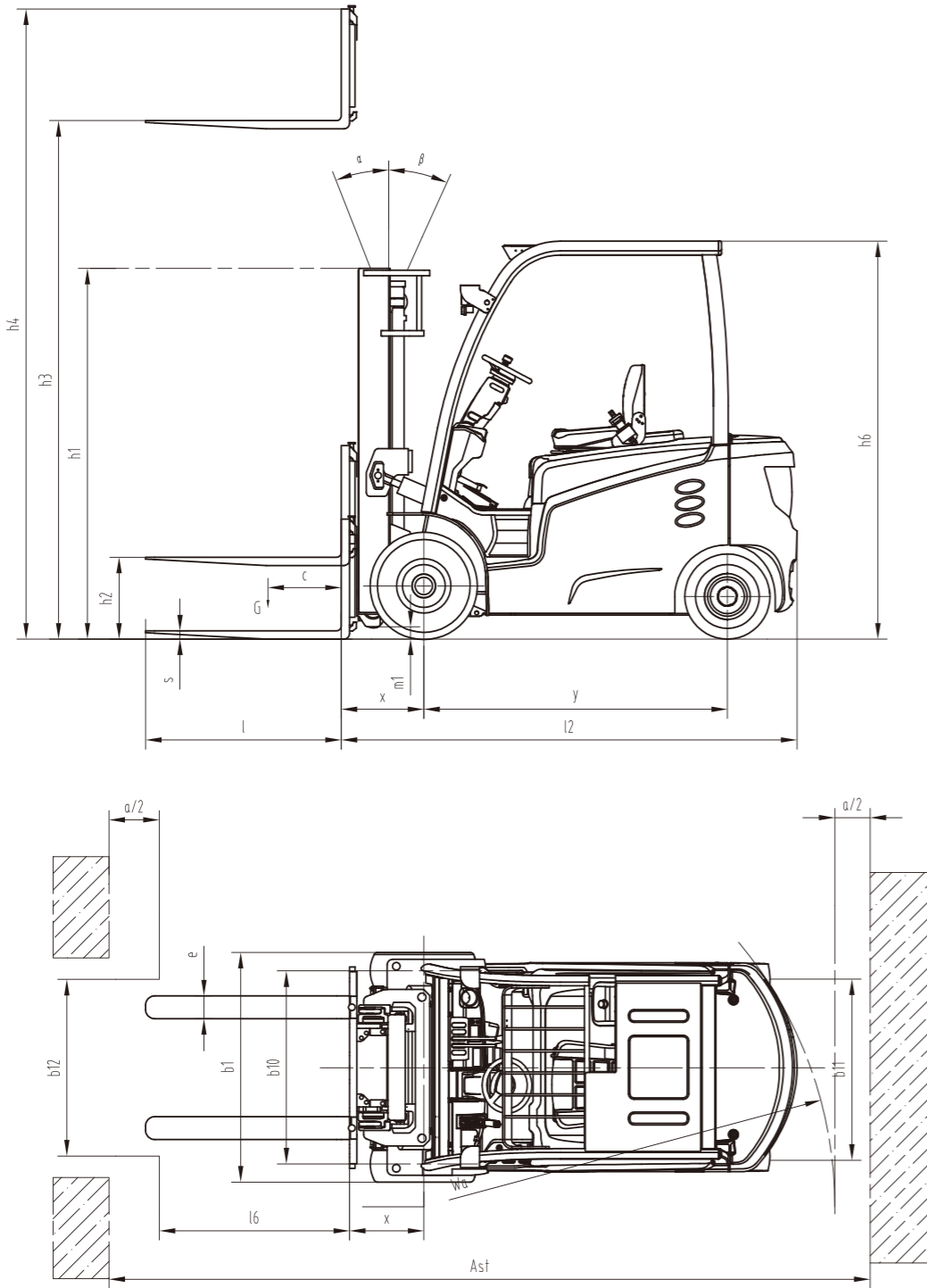

$Ast = l6 + x + Wa + a$ $l6$: Load Length a : Clearance (200mm)

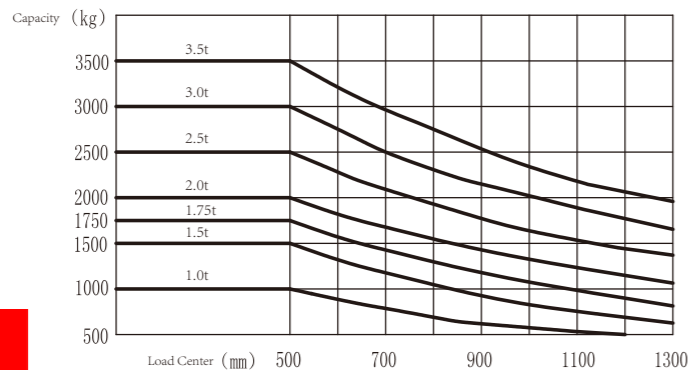

1.0~2.0t X Series Mast Specification

Type	Model	Lifting height	Lowered overall height	Overall height		Free lifting height		Tilting range		Load Capacity at 500 mm LC							
				With backrest	Without backrest	With backrest	Without backrest	FWD	BWD	Single Tire				Double Tire			
				mm	mm	mm	mm	mm	mm	(°)	(°)	1.0t	1.5t	1.8t	2.0t	1.0t	1.5t
Duplex wide view mast	M250	2500	1742	3455	3048	155	155	6	6	1000	1500	1750	2000	1000	1500	1750	2000
	M270	2700	1842	3655	3248	155	155	6	6	1000	1500	1750	2000	1000	1500	1750	2000
	M300	3000	1992	3955	3548	155	155	6	10	1000	1500	1750	2000	1000	1500	1750	2000
	M330	3300	2142	4255	3848	155	155	6	10	1000	1500	1750	2000	1000	1500	1750	2000
	M350	3500	2242	4455	4048	155	155	6	10	1000	1500	1750	2000	1000	1500	1750	2000
	M370	3700	2392	4655	4248	155	155	6	10	1000	1500	1750	2000	1000	1500	1750	2000
	M400	4000	2592	4955	4548	155	155	6	10	1000	1500	1750	2000	1000	1500	1750	2000
	M430	4300	2742	5255	4848	155	155	6	6	1000	1500	1700	1900	1000	1500	1750	1950
	M450	4500	2842	5455	5048	155	155	6	6	1000	1500	1650	1800	1000	1500	1700	1850
	M500	5000	3092	5955	5548	155	155	6	6	1000	1400	1550	1700	1000	1500	1650	1750
M550	5500	3342	6455	6048	155	155	3	6	1000	1250	1500	1600	1000	1350	1600	1650	
M600	6000	3592	6955	6548	155	155	3	6	1000	1100	1300	1400	1000	1200	1400	1450	
Duplex full-free lifting mast	U250	2500	1742	3445	3060	797	1182	6	6	1000	1500	1750	2000	1000	1500	1750	2000
	U270	2700	1842	3645	3260	897	1282	6	6	1000	1500	1750	2000	1000	1500	1750	2000
	U300	3000	1992	3945	3560	1047	1432	6	10	1000	1500	1750	2000	1000	1500	1750	2000
	U330	3300	2142	4245	3860	1197	1582	6	10	1000	1500	1750	2000	1000	1500	1750	2000
	U350	3500	2242	4445	4060	1297	1682	6	10	1000	1500	1750	2000	1000	1500	1750	2000
	U370	3700	2342	4645	4260	1397	1782	6	10	1000	1500	1750	2000	1000	1500	1750	2000
	U400	4000	2542	4945	4560	1597	1982	6	10	1000	1500	1750	2000	1000	1500	1750	2000
	N400	4000	1892	4955	4572	947	1330	6	6	1000	1500	1750	1900	1000	1500	1750	1950
	N430	4300	1992	5255	4872	1047	1430	6	6	1000	1500	1650	1850	1000	1500	1750	1900
	N450	4500	2042	5455	5072	1097	1480	6	6	1000	1500	1650	1800	1000	1500	1750	1850
Triplex full-free lifting mast	N470	4700	2112	5645	5262	1167	1550	6	6	1000	1450	1600	1750	1000	1500	1700	1800
	N480	4800	2142	5755	5372	1197	1580	6	6	1000	1450	1600	1750	1000	1500	1700	1800
	N500	5000	2242	5955	5572	1297	1680	6	6	1000	1400	1550	1700	1000	1500	1650	1750
	N550	5500	2412	6455	6062	1467	1850	3	6	1000	1250	1500	1600	1000	1350	1600	1650
	N600	6000	2612	6945	6562	1667	2050	3	6	1000	1100	1300	1400	1000	1200	1400	1450
	N650	6500	2867	7455	7072	1922	2305	3	6	900	900	1150	1200	1000	1000	1200	1250
	N700	7000	3042	7955	7572	2097	2480	3	6	650	700	950	1000	700	800	1000	1050

2.0~2.5t X Series Mast Specification

Type	Model	Lifting height	Lowered overall height	Overall height		Free lifting height		Tilting range		Load Capacity at 500 mm LC					
				With backrest	Without backrest	With backrest	Without backrest	FWD	BWD	Single Tire			Double Tire		
				mm	mm	mm	mm	mm	mm	(°)	(°)	2.0t	2.5t	2.5t L	2.0t
Duplex wide view mast	M250	2500	1761	3546	3143	140	140	6	6	2000	2500	2500	2000	2500	2500
	M270	2700	1861	3746	3343	140	140	6	6	2000	2500	2500	2000	2500	2500
	M300	3000	2011	4046	3643	140	140	6	10	2000	2500	2500	2000	2500	2500
	M330	3300	2161	4346	3943	140	140	6	10	2000	2500	2500	2000	2500	2500
	M350	3500	2261	4546	4143	140	140	6	10	2000	2500	2500	2000	2500	2500
	M370	3700	2411	4746	4343	140	140	6	10	2000	2500	2500	2000	2500	2500
	M400	4000	2611	5046	4643	140	140	6	10	2000	2500	2500	2000	2500	2500
	M430	4300	2761	5346	4943	140	140	6	6	2000	2500	2500	2000	2500	2500
	M450	4500	2861	5546	5143	140	140	6	6	2000	2450	2500	2000	2500	2500
	M500	5000	3111	6046	5643	140	140	6	6	1850	2150	2200	2000	2200	2250
Duplex full-free lifting mast	U250	2500	1761	3546	3163	715	1098	6	6	2000	2500	2500	2000	2500	2500
	U270	2700	1861	3746	3363	815	1198	6	6	2000	2500	2500	2000	2500	2500
	U300	3000	2011	4046	3663	965	1348	6	10	2000	2500	2500	2000	2500	2500
	U330	3300	2161	4346	3963	1115	1498	6	10	2000	2500	2500	2000	2500	2500
	U350	3500	2261	4546	4163	1215	1598	6	10	2000	2500	2500	2000	2500	2500
	U370	3700	2361	4746	4363	1315	1698	6	10	2000	2500	2500	2000	2500	2500
	U400	4000	2561	5046	4663	1515	1898	6	10	2000	2500	2500	2000	2500	2500
	N400	4000	1911	5046	4663	865	1248	6	6	2000	2500	2500	2000	2500	2500
	N430	4300	2011	5346	4963	965	1348	6	6	2000	2450	2500	2000	2500	2500
	N450	4500	2061	5546	5163	1015	1398	6	6	2000	2350	2400	2000	2450	2500
Triplex full-free lifting mast	N470	4700	2136	5746	5363	1090	1473	6	6	1950	2250	2300	2000	2350	2400
	N480	4800	2161	5846	5463	1115	1498	6	6	1950	2250	2300	2000	2350	2400
	N500	5000	2236	6046	5663	1190	1573	6	6	1850	2150	2200	2000	2250	2300
	N550	5500	2411	6546	6163	1365	1748	3	6	1750	2050	2100	1900	2100	2150
	N600	6000	2611	7046	6663	1565	1948	3	6	1550	1850	1900	1800	1950	2000
	N650	6500	2861	7546	7163	1815	2198	3	6	1300	1600	1650	1550	1800	1850
	N700	7000	3061	8046	7663	2015	2398	3	6	1050	1350	1400	1300	1600	1650

3.0~3.5t X Series Mast Specification

Type	Model	Lifting height	Lowered overall height		Overall height		Free lifting height		Tilting range		Load Capacity at 500 mm LC							
			3.0t	3.5t	With backrest	Without backrest	With backrest	Without backrest	FWD	BWD	Single Tire		Double Tire					
			mm	mm	mm	mm	mm	mm	mm	mm	(°)	(°)	3.0t	3.5t	3.0t	3.5t		
Duplex wide view mast	M250	2500	1767	1917	3645	3645	3177	3277	135	140	135	140	6	6	3000	3500	3000	3500
	M270	2700	1867	2017	3845	3845	3377	3477	135	140	135	140	6	6	3000	3500	3000	3500
	M300	3000	2017	2167	4145	4145	3687	3787	135	140	135	140	6	10	3000	3500	3000	3500
	M330	3300	2167	2317	4445	4445	3977	4077	135	140	135	140	6	10	3000	3500	3000	3500
	M350	3500	2267	2417	4645	4645	4177	4277	135	140	135	140	6	10	3000	3500	3000	3500
	M370	3700	2417	2517	4845	4845	4377	4477	135	140	135	140	6	10	3000	3500	3000	3500
	M400	4000	2617	2767	5145	5145	4677	4777	135	140	135	140	6	10	3000	3500	3000	3500
	M430	4300	2767	2917	5445	5445	4977	5077	135	140	135	140	6	6	3000	3400	3000	3500
	M450	4500	2867	3017	5645	5645	5177	5277	135	140	135	140	6	6	3000	3300	3000	3400
	M500	5000	3117	3267	6145	6145	5677	5777	135	140	135	140	6	6	2850	3100	2900	3200
Duplex full-free lifting mast	M550	5500	3367	3517	6645	6645	6177	6277	135	140	135	140	3	6	2670	3000	2750	3100
	M600	6000	3617	3767	7145	7145	6677	6777	135	140	135	140	3	6	2350	2650	2500	2800
	U250	2500	1817	1932	3645	3645	3226	3316	672	787	1091	1116	6	6	3000	3500	3000	3500
	U270	2700	1917	2032	3845	3845	3426	3516	772	887	1191	1216	6	6	3000	3500	3000	3500
	U300	3000	2067	2182	4145	4145	3726	3816	922	1037	1341	1366	6	10	3000	3500	3000	3500
	U330	3300	2217	2332	4445	4445	4026	4116	1072	1187	1491	1516	6	10	3000	3500	3000	3500
	U350	3500	2317	2432	4645	4645	4226	4316	1172	1287	1591	1666	6	10	3000	3500	3000	3500
	U370	3700	2417	2532	4845	4845												