



XC SERIES REACH TRUCK WITH LITHIUM POWER

with capacity of 1,400 to 2,500kg



Heavy Lift Forklifts P/L

Factory site: 826 Mountain Hwy, Bayswater Vic 3153

Tel: 03 9762 49655

Sales@heavyliftforklifts.com.au



Follow us on Facebook



Follow us on YouTube



Follow us on WeChat



Download "Hangcha Forklift" App



ISO14001
ISO14001:2015



ISO9001
ISO9001:2015



HANGCHA trucks conform to the European Safety Requirements.

2021 VERSION 2/COPYRIGHT 2021/T2

HANGCHA GROUP CO., LTD. reserves the right to make any changes without notice concerning colors, equipment, or specifications detailed in this brochure, or to discontinue individual models. The colors of trucks, delivered may differ slightly from those in brochures.

The World of Hangcha
SINCE 1956



A NEW DIMENSION OF PERFORMANCE

XC SERIES REACH TRUCK WITH LITHIUM POWER

- / The XC series reach truck with lithium power fully utilize the advantages of lithium battery and achieve disruptive innovations in vehicle structure, functional configuration, performance parameters, ergonomics, and operating vision.
- / We cater for a wide range of applications whilst ensuring optimum energy efficiency. Regardless of your special requirements – whether confined spaces or lifting height reaches 13m, load capacity of up to 2,500 kg or individual customisation with various options – we have the truck you need.
- / Compact size of the lithium battery pack and breaking through the traditional structure design, makes the truck style more novel and more efficient.

MAXIMUM TRAVELLING SPEED

14km/h

MAXIMUM LIFTING SPEED

0.81m/s

HIGH RESIDUAL CAPACITY

6,500mm

MAXIMUM LOAD CAPACITY

2,500kg

MAXIMUM LIFT HEIGHT

13,000mm



BEING ENVIRONMENTALLY FRIENDLY, EFFICIENT AND DURABLE

- / CATL lithium battery is standard for all series, adopting 80V voltage system which can provides fast charging and long service life and less energy loss.
- / The special-shaped lithium battery pack design provides a large operating space in the cab and a broad view.



Charging port



Battery removal

 Working time **> 10h**

 Fast charging time **≤ 2h**

| Lithium battery capacity | | |
|--------------------------|------|-----------|
| 1.4 t | Std. | 80V/250Ah |
| 1.6 t | | 80V/404Ah |
| 1.8 t | Opt. | 80V/404Ah |
| 2.0 t | Std. | 80V/404Ah |
| 2.5 t | | 80V/404Ah |



A NOVEL PROFILE STYLE AND COMPACT INTERIOR DESIGN

With fewer exposed fasteners of the inside covers, the interior is compact and stylish.

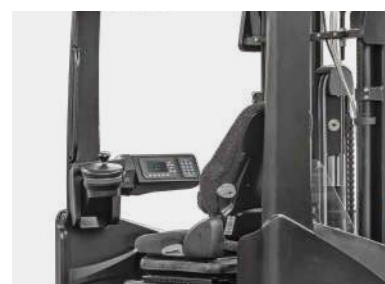
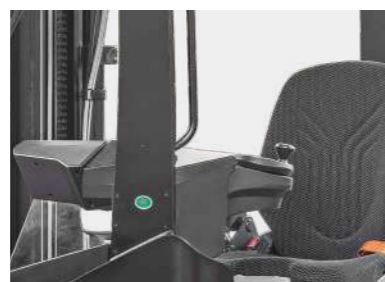

Thanks to the special-shaped design of the battery pack and the breakthrough in the body structure, which can provide a wider view.



The improved mast structure and piping arrangement enables a broader vision for stacking operations

/ The hydraulic tubing and the wires are on both sides of the mast, overlapping with the chain, making full use of the space and reducing the line of sight.



The compact mast design enables operator have a wider view around the outside of the mast.

The middle cylinder is arranged eccentrically to enable the driver to have a wider view around the inside of the mast.

EXCELLENT ERGONOMIC DESIGN

Dashboard angle adjustment

Control with a fingertip switch



Steering wheel position can also be adjusted



The pedal height can be adjusted electrically

Integral suspended seat

MULTIFUNCTIONAL INTERACTIVE COLOR-SCREEN INSTRUMENTS

The new multifunctional 4.3 inch color-screen instruments developed for the XC series reach truck have easier human-machine interfaces.



More status indication



1

1. Lifting height
2. Local time
3. Load weight

2

1. Driving mode
2. Fork action
3. Operating time
4. Maximum allowable lifting height

3

1. Steering mode
2. Battery power
3. Travelling speed

4

Various status signs and warning signs are displayed in a queue according to actual needs

More convenient shortcut button

Thanks to the integrated design of the instrument function buttons, the truck console saves a lot of physical buttons, making it more concise and efficient.



5

Height selection

6

Height limit

7

Lighting control

8

Battery removal

9

Optional function switching screen

10

↑ Button Driving mode switching

11

↓ Button Turtle speed mode

COMPREHENSIVELY IMPROVED FUNCTION CONFIGURATION



Height selection

Multiple heights can be pre-set on the instrument. After the function is enabled, when the fork is about to be lifted to the preset height, the lifting speed will gradually slow down and the fork will finally stop at the set height steadily.



Height limit

After this function is enabled, when the fork is lifted to a certain height, this height will be set as the maximum allowable lifting height. Afterwards, whenever the fork is about to be lifted to this height, the lifting speed will gradually slow down and the fork will steadily finally stop at this height.

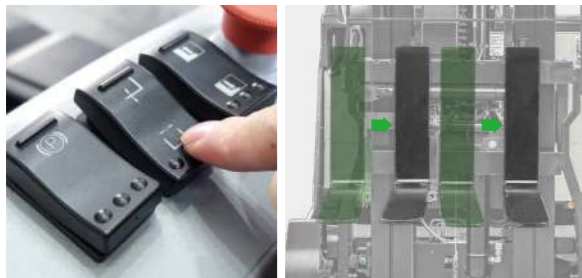

Central sideshift

Simple, reliable and fast: The central positioning of the sideshift occurs automatically, eliminating the time-consuming, cautious approach of the required position. (Only for fingertip system)

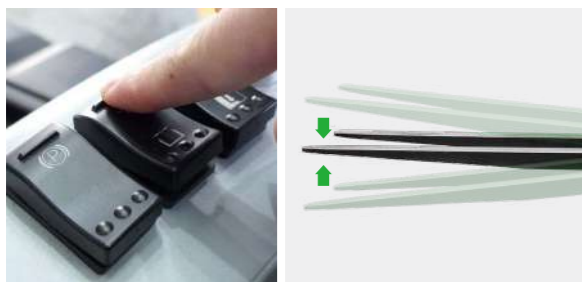

Horizontal fork

Particularly at high lift heights, the forks' tilt position is often very hard to detect. The automatic horizontal positioning significantly simplifies and accelerates pallet entry. (Only for fingertip system)



Faster, easier and safer stacking and retrieval operations

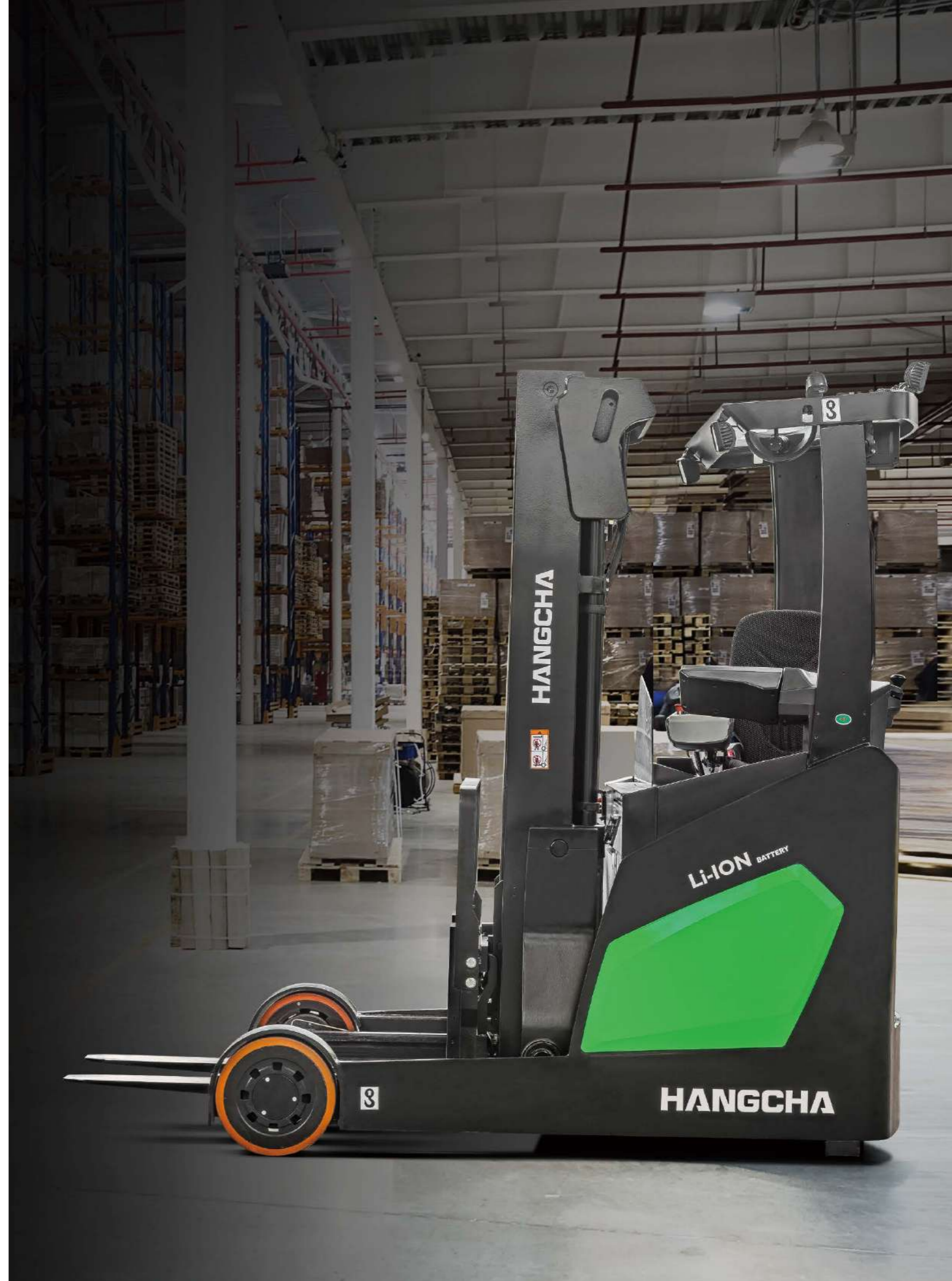

SAFETY FROM EVERY ANGLE

Drive control limit

Drive control limits the travelling speed and traverse speed as soon as the forks are raised. This increases the safety when manoeuvring with a raised pallet in front of the storage rack, while still ensuring more sensitive manoeuvring during the work cycle.

Traverse speeds (mm/s)

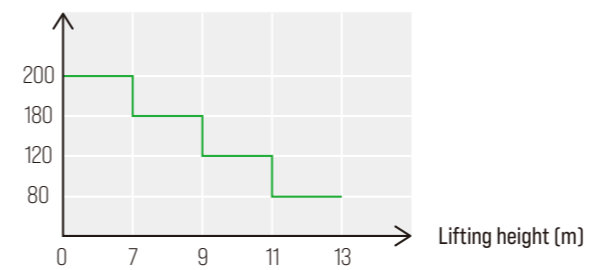

Travelling speed (km/h)

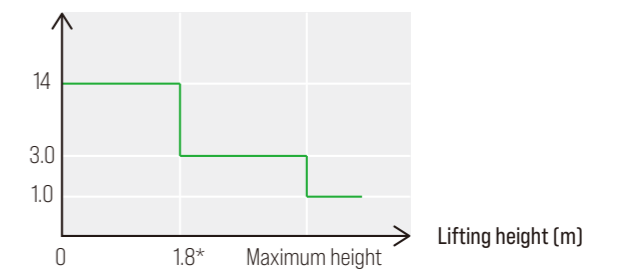

Note: The above table is only for 2.0/2.5t, the parameters of other models are not the same.

*: 1.8m is only for the fingertip system. The parameter of mechanical control system is the height of free lift.



The battery is in an inappropriate position and the indicator light is lit

Battery lock with creep speed interlock

Installed on the battery latch in the motor compartment. Monitors the locking of the battery pack. If the battery pack is not retracted or not locked, travel is restricted to creep speed.



EASY MAINTENANCE

The battery pack can be replaced quickly. The driver can unlock and remove the battery while sitting on his seat.

Remove battery pack step



The hood can be easily dismantled and mounted to facilitate routine maintenance operations.

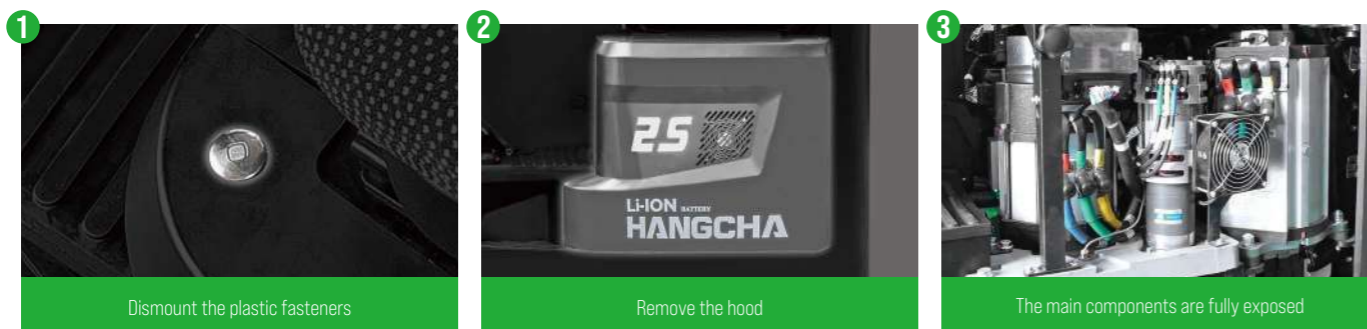

The seat can be turned open at a large angle, which is convenient for maintenance work.

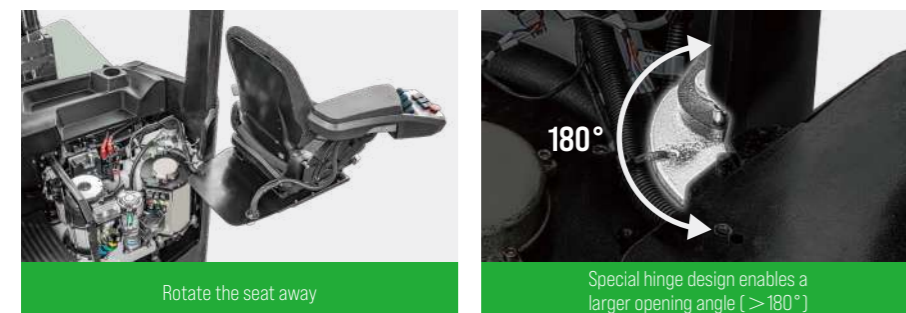

WE GIVE YOU ALL THE OPTIONS



Stacking and retrieval via video monitoring

Our video camera allows for the precise and quick access of extremely high locations. The position of the camera on the forks enables operators to efficiently and reliably control stacking and retrieval operations from their seating position/viewpoint. They no longer have to look up, which noticeably reduces the strain on their shoulders and neck. Also, information on the pallets is easily visible, even at great heights.

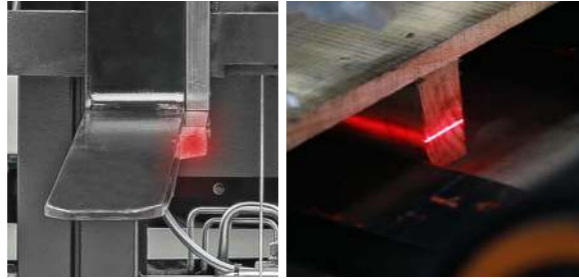

Easier stacking and retrieval with positioning laser

Our positioning lasers significantly simplify the stacking and retrieval process and increase the safety for load and rack. The laser sources are integrated into the fork tips, projecting a red line on the area ahead. This allows the operator to adjust the fork more accurately to be able to drive effortlessly into the pallet.



Easy access

Easy access protects the reach truck against unauthorised use. Authorisation management is directly controlled via the truck's display. Customised to your requirements and company size – you can choose between the key(Std.), PIN code and transponder.



Safety at any blind spots with Floor Spot

Floor Spot projects a blue dot on the floor around the truck. Especially at blind intersections or at the end of rack aisles, the Floor Spot alerts an approaching truck in time to respond.



100% clear view thanks to panorama roof panel

Maximum visibility: The panorama roof panel without cross beams provides maximum visibility of the goods and forks.



Optimum traction via traction control system

Optimum traction is ensured with braking of the drive wheel, which would otherwise spin on wet or dusty floors.



XC Series Reach Truck With Lithium Power Specification

| Distinguishing mark | HANGCHA GROUP CO.,LTD. | | | | | | | | |
|---------------------|-------------------------------------|--|-------------------------------|-------------------------------|-------------------------------|-------------------------------|-------------------------------|-----------------------|--|
| | | | CQD14-XC4-SI CQD14-XC4D-SI | CQD16-XC4-SI CQD16-XC4D-SI | CQD18-XC4-SI CQD18-XC4D-SI | CQD20-XC4-SI CQD20-XC4D-SI | CQD25-XC4-SI CQD25-XC4D-SI | | |
| 1.1 | Manufacturer | | HANGCHA GROUP CO.,LTD. | | | | | | |
| 1.2 | Model | | CQD14-XC4-SI CQD14-XC4D-SI | CQD16-XC4-SI CQD16-XC4D-SI | CQD18-XC4-SI CQD18-XC4D-SI | CQD20-XC4-SI CQD20-XC4D-SI | CQD25-XC4-SI CQD25-XC4D-SI | | |
| 1.3 | Power unit | | Li-ION battery | Li-ION battery | Li-ION battery | Li-ION battery | Li-ION battery | | |
| 1.4 | Manual | | Seated | Seated | Seated | Seated | Seated | | |
| 1.5 | Rated capacity/rated load | Q(t) | 1.4 | 1.6 | 1.8 | 2 | 2.5 | | |
| 1.6 | Load centre distance | c(mm) | 600 | 600 | 600 | 600 | 600 | | |
| 1.8 | Load distance | x(mm) | 360 ^{[7][10]} | 410 ^{[7][11]} | 385 ^[8] | 362 ^[20] | 484 ^[23] | | |
| 1.8.1 | Load distance, mast reached forward | x1(mm) | 211 ^[2] | 211 ^[2] | 203 | 232 | 232 | | |
| 1.9 | Wheelbase | y(mm) | 1355 | 1405 | 1405 | 1471 | 1601 | | |
| Weight | 2.1 | Net weight incl. battery (see row 6.5) | (kg) | 3400 | 3440 | 3730 | 3830 | 3980 | |
| Tyres, chassis | 3.1 | Tyres | | PU | PU | PU | PU | PU | |
| | 3.2 | Tyre size, front | | φ343×140 | φ343×140 | φ343×140 | φ343×140 | φ400×160 | |
| | 3.3 | Tyre size, rear | | φ285×100 | φ285×100 | φ285×100 | φ343×108 | φ343×108 | |
| | 3.5 | Wheels, number front/rear (x = driven wheels) | | 1x/2 | 1x/2 | 1x/2 | 1x/2 | 1x/2 | |
| | 3.7 | Tread width, rear | b1(mm) | 1174 | 1174 | 1174 | 1162 | 1162 | |
| Dimensions | 4.1 | Tilt of fork carriage forward/backward | α/β(°) | 2.0/5.0 | 2.0/5.0 | 2.0/5.0 | 2.0/5.0 | 2.0/5.0 | |
| | 4.2 | Height, mast lowered | h1(mm) | 2300 | 2300 | 2315 | 2315 | 2315 | |
| | 4.3 | Free lift | h2(mm) | 1419 | 1419 | 1529 | 1529 | 1529 | |
| | 4.4 | Lift | h3(mm) | 5000 | 5000 | 5000 | 5000 | 5000 | |
| | 4.5 | Height, mast extended | h4(mm) | 5746 | 5746 | 5746 | 5746 | 5746 | |
| | 4.7 | Height of overhead guard | h6(mm) | 2263 | 2263 | 2263 | 2263 | 2263 | |
| | 4.8 | Seat height | h7(mm) | 1159 | 1159 | 1159 | 1159 | 1159 | |
| | 4.10 | Height of support arms | h8(mm) | 308 | 308 | 308 | 365.5 | 365.5 | |
| | 4.19 | Overall length | h(mm) | 2400 ^{[3][12]} | 2400 ^{[3][12]} | 2425 ^[1] | 2514 ^[21] | 2542 ^[21] | |
| | 4.20 | Length to face of forks | l2(mm) | 1250 ^{[3][12]} | 1250 ^{[3][12]} | 1275 ^[1] | 1364 ^[23] | 1392 ^[23] | |
| | 4.21 | Overall width | b1/b2(mm) | 1270/1270 | 1270/1270 | 1270/1270 | 1270/1270 | 1270/1270 | |
| | 4.22 | Fork dimensions | s/e/l(mm) | 35×120×1150 | 35×120×1150 | 40×122×1150 | 40×122×1150 | 40×122×1150 | |
| | 4.23 | Fork carriage ISO 2328, class/type A, B | | II A | II A | II A | II A | II A | |
| | 4.24 | Fork-carriage width | b3(mm) | 830 | 830 | 830 | 830 | 830 | |
| | 4.25 | Distance between fork-arms | b5(mm) | 750 | 750 | 750 | 750 | 750 | |
| | 4.26 | Distance between wheel arms | b4(mm) | 940 | 940 | 940 | 940 | 940 | |
| | 4.28 | Reach distance | l4(mm) | 571 ^{[4][13]} | 621 ^{[4][13]} | 588 ^[8] | 594 ^[20] | 716 ^[20] | |
| | 4.32 | Ground clearance, centre of wheelbase | m2(mm) | 80 | 80 | 80 | 80 | 80 | |
| | 4.33 | Aisle width for pallets 1000 × 1200 sideways | Aa1(mm) | 2687 ^{[5][14]} | 2701 ^{[5][14]} | 2719 ^[8] | 2802 ^[21] | 2867 ^[24] | |
| | 4.34 | Aisle width for pallets 800 × 1200 lengthways | Aa1(mm) | 2740 ^{[6][15]} | 2745 ^{[6][15]} | 2768 ^[8] | 2855 ^[23] | 2896 ^[25] | |
| 4.35 | Turning radius | Wa(mm) | 1610 | 1660 | 1660 | 1726 | 1876 | | |
| 4.37 | Length over the support arms | l1(mm) | 1775 | 1825 | 1825 | 1920 | 2070 | | |
| Performance data | 5.1 | Travel speed, laden/unladen | (km/h) | 14/14 | 14/14 | 14/14 | 14/14 | 14/14 | |
| | 5.2 | Lift speed, laden/unladen | (m/s) | 0.61/0.81 | 0.59/0.81 | 0.5/0.7 | 0.48/0.7 | 0.45/0.7 | |
| | 5.3 | Lowering speed, laden/unladen | (m/s) | 0.56/0.56 | 0.56/0.56 | 0.56/0.56 | 0.56/0.56 | 0.56/0.56 | |
| | 5.4 | Traverse speed w. / w.o. load | (m/s) | 0.24/0.24 | 0.24/0.24 | 0.2/0.2 | 0.2/0.2 | 0.2/0.2 | |
| | 5.8 | Max. gradeability, laden/unladen 5min | (%) | 10.0/15.0 | 10.0/15.0 | 10.0/15.0 | 10.0/15.0 | 10.0/15.0 | |
| | 5.10 | Service brake | | Electromagnetic | Electromagnetic+Mech. | Electromagnetic+Mech. | Electromagnetic+Mech. | Electromagnetic+Mech. | |
| Electric-engine | 6.1 | Drive motor rating S2 60 min. | (kW) | 8.1 | 8.1 | 8.1 | 8.1 | 8.1 | |
| | 6.2 | Lift motor rating at S3 15% | (kW) | 20 | 20 | 20 | 20 | 20 | |
| | 6.3 | Battery as per DIN 43531 /35/36 A, B, C, no | | no | no | no | no | no | |
| | 6.4 | Battery voltage, nominal capacity K5 | (V/Ah) | 80/250 | 80/250 | 80/250 | 80/404 | 80/404 | |
| | 6.4.1 | Battery voltage, rated capacity K5, Optional | (V/Ah) | 80/404 | 80/404 | 80/404 | - | - | |
| 6.5 | Battery weight (+5%) | (kg) | 275 | 275 | 275 | 360 | 360 | | |
| Addition data | 10.1 | Operating pressure for attachments | (bar) | 150 | 150 | 150 | 150 | 150 | |
| | 10.2 | Oil flow for attachments | (l/min) | 18 | 18 | 18 | 18 | 18 | |
| | 10.7 | Sound pressure level LpAZ (at the driver's seat) | (db(A)) | 68 | 68 | 68 | 68 | 68 | |

Note: 1) h3>7000mm:-25mm. 2) h3>7000mm:-8mm. 3) h3>7000mm:+25mm. 4) h3>7000mm:-33mm. 5) h3>7000mm:+19mm. 6) h3>7000mm:+23mm. 7) With optional battery 80V/404Ah,h3>7000mm:-90mm.

8) With optional battery 80V/404Ah, h3>7000mm: +90mm. 9) With optional battery 80V/404Ah, h3>7000mm: +68mm. 10) With optional battery 80V/404Ah, h3>7000mm: +82mm. 11) With optional battery 80V/404Ah, h3>7000mm:-115mm.

12) With optional battery 80V/404Ah, h3>7000mm: +115mm. 13) With optional battery 80V/404Ah, h3>7000mm: -123mm. 14) With optional battery 80V/404Ah, h3>7000mm: +87mm. 15) With optional battery 80V/404Ah, h3>7000mm: +105mm.

16) With optional battery 80V/404Ah:-90mm. 17) With optional battery 80V/404Ah: +90mm. 18) With optional battery 80V/404Ah: +67mm. 19) With optional battery 80V/404Ah: +81m. 20) h3>12000mm:-150mm. 21) h3>12000mm:+150mm.

22) h3>12000mm:+115mm. 23) h3>12000mm:+137mm. 24) h3>12000mm:+105mm. 25) h3>12000mm:+134mm.

Features

| NO. | System | Features | CQD14/16/18/20/25-XC4-SI | CQD14/16/18/20/25-XC4D-SI |
|-----|---|--|-----------------------------------|-----------------------------------|
| 1 | Control | Control with a mechanical control lever | ● | / |
| 2 | | Control with a fingertip switch | / | ● |
| 3 | | Height display | ○ (Excluding the free lift range) | ● (Including the free lift range) |
| 4 | | Height selection | ○ (Excluding the free lift range) | ● (Including the free lift range) |
| 5 | | Height limit | ○ (Excluding the free lift range) | ● (Including the free lift range) |
| 6 | | Central sideshift | / | ● |
| 7 | | Horizontal fork alignment | / | ● |
| 8 | | Mast reach damping system | ● | ● |
| 9 | | Electric lowering limit - Stop forks above outriggers if mast is retracted | ○ | ● |
| 10 | | Soft landing system | / | ● |
| 11 | | Lifting damping system | ● | ● |
| 12 | | Drive control limit | ● | ● |
| 13 | | Drive wheel skid control system | ○ | ○ |
| 14 | | Battery lock with creep speed interlock | ● | ● |
| 15 | | Travelling speed control at corner | ● | ● |
| 16 | | 180° steering mode | ● | ● |
| 17 | | 360° steering mode | ○ | ○ |
| 18 | Transmission system | ZF transmission | ● | ● |
| 19 | Electronic accessories | USB power socket | ● | ● |
| 20 | | Fork positioning laser | ○ | ○ |
| 21 | | Video monitoring | ○ | ○ |
| 22 | | Keyed start | ● | ● |
| 23 | | Start with a PIN code or by a card | ○ | ○ |
| 24 | | Beep | ○ | ○ |
| 25 | | Operating light (in the direction of the fork) | ● | ● |
| 26 | | Operating light (in the reverse direction of the fork) | ○ | ○ |
| 27 | | Alarm light | ● | ● |
| 28 | | Blue light | ○ | ○ |
| 29 | Three-sided one line laser projection light | ○ | ○ | |
| 30 | Ergonomic design | Electrical adjustment of pedal height | ○ | ● |
| 31 | | Adjustable steering wheel | ● | ● |
| 32 | Instrument angle adjustment | ● | ● | |
| 33 | Fault Diagnosis | Suctioned oil filter clogging alarm | ○ | ● |
| 34 | | Backflow oil filter clogging alarm | ○ | ● |
| 35 | Seat | Sequential Seat Belt Interlock System | ● | ● |
| 36 | | BF6-3 suspension seat | ● | / |
| 37 | | MS665/522 suspension seat | ○ | ● |
| 38 | Other | Panorama roof | ○ | ○ |
| 39 | | PVC ceiling | ○ | ○ |
| 40 | | Curved rearview mirror | ○ | ○ |
| 41 | | Left and right rear view mirrors | ○ | ○ |
| 42 | | Cold storage | ○ | ○ |
| 43 | | Load backrest | ● | ● |
| 44 | | Fire extinguisher | ○ | ○ |
| 45 | | Electric fan | ○ | ○ |
| 46 | OPS system | ● | ● | |

Note: ● Standard; ○ Optional

1.4/1.6t Mast Specification

| Type | Lifting height h3 | Mast lowered h1 | Mast extended h4 | Free lifting height h2 | Tilting range |
|-----------------------------|-------------------|-----------------|------------------|------------------------|---------------|
| | mm | mm | mm | mm | (°) |
| Free triplex wide-view mast | 4000 | 2030 | 4965 | 1065 | 2/5 |
| | 4500 | 2150 | 5465 | 1185 | 2/5 |
| | 5000 | 2300 | 5965 | 1335 | 2/5 |
| | 5500 | 2450 | 6465 | 1485 | 2/5 |
| | 6000 | 2625 | 6965 | 1660 | 2/5 |
| | 6500 | 2800 | 7465 | 1835 | 2/5 |
| | 7000 | 3000 | 7965 | 2035 | 2/5 |
| | 7500 | 3060 | 8465 | 2095 | 2/5 |
| | 8000 | 3250 | 8965 | 2285 | 2/5 |
| | 8500 | 3420 | 9465 | 2455 | 2/5 |
| | 9000 | 3580 | 9965 | 2615 | 2/5 |
| | 9500 | 3760 | 10465 | 2795 | 2/5 |
| | 10000 | 3920 | 10965 | 2955 | 2/5 |
| | 10500 | 4100 | 11465 | 3135 | 2/5 |
| 11000 | 4300 | 11965 | 3335 | 2/5 | |

1.8t Mast Specification

| Type | Lifting height h3 | Mast lowered h1 | Mast extended h4 | Free lifting height h2 | Tilting range |
|-----------------------------|-------------------|-----------------|------------------|------------------------|---------------|
| | mm | mm | mm | mm | (°) |
| Free triplex wide-view mast | 4000 | 2085 | 4965 | 1120 | 2/5 |
| | 4500 | 2165 | 5465 | 1200 | 2/5 |
| | 5000 | 2315 | 5965 | 1350 | 2/5 |
| | 5500 | 2490 | 6465 | 1525 | 2/5 |
| | 6000 | 2665 | 6965 | 1700 | 2/5 |
| | 6500 | 2835 | 7465 | 1870 | 2/5 |
| | 7000 | 3020 | 7965 | 2055 | 2/5 |
| | 7500 | 3180 | 8465 | 2215 | 2/5 |
| | 8000 | 3350 | 8965 | 2385 | 2/5 |
| | 8500 | 3580 | 9465 | 2615 | 2/5 |
| | 9000 | 3800 | 9965 | 2835 | 2/5 |
| | 9500 | 3970 | 10465 | 3005 | 2/5 |
| | 10000 | 4100 | 10965 | 3135 | 2/5 |
| | 10500 | 4250 | 11465 | 3285 | 2/5 |
| 11000 | 4450 | 11965 | 3485 | 2/5 | |
| 11500 | 4700 | 12465 | 3735 | 2/5 | |

2.0t Mast Specification

| Type | Lifting height h3 | Mast lowered h1 | Mast extended h4 | Free lifting height h2 | Tilting range |
|-----------------------------|-------------------|-----------------|------------------|------------------------|---------------|
| | mm | mm | mm | mm | (°) |
| Free triplex wide-view mast | 4000 | 2085 | 4965 | 1120 | 2/5 |
| | 4500 | 2165 | 5465 | 1200 | 2/5 |
| | 5000 | 2315 | 5965 | 1350 | 2/5 |
| | 5500 | 2490 | 6465 | 1525 | 2/5 |
| | 6000 | 2665 | 6965 | 1700 | 2/5 |
| | 6500 | 2835 | 7465 | 1870 | 2/5 |
| | 7000 | 3020 | 7965 | 2055 | 2/5 |
| | 7500 | 3180 | 8465 | 2215 | 2/5 |
| | 8000 | 3350 | 8965 | 2385 | 2/5 |
| | 8500 | 3580 | 9465 | 2615 | 2/5 |
| | 9000 | 3800 | 9965 | 2835 | 2/5 |
| | 9500 | 3970 | 10465 | 3005 | 2/5 |
| | 10000 | 4100 | 10965 | 3135 | 2/5 |
| | 10500 | 4250 | 11465 | 3285 | 2/5 |
| | 11000 | 4450 | 11965 | 3485 | 2/5 |
| | 11500 | 4700 | 12465 | 3735 | 2/5 |
| 12000* | 4900 | 12965 | 3935 | 2/5 | |
| 12500* | 5150 | 13465 | 4185 | 2/5 | |
| 13000* | 5400 | 13965 | 4435 | 2/5 | |

* When you choose the mast, the dimensions of the truck will be affected. Please refer to the performance parameter table for details.

2.5t Mast Specification

| Type | Lifting height h3 | Mast lowered h1 | Mast extended h4 | Free lifting height h2 | Tilting range |
|-----------------------------|-------------------|-----------------|------------------|------------------------|---------------|
| | mm | mm | mm | mm | (°) |
| Free triplex wide-view mast | 4000 | 2085 | 4965 | 1120 | 2/5 |
| | 4500 | 2165 | 5465 | 1200 | 2/5 |
| | 5000 | 2315 | 5965 | 1350 | 2/5 |
| | 5500 | 2490 | 6465 | 1525 | 2/5 |
| | 6000 | 2665 | 6965 | 1700 | 2/5 |
| | 6500 | 2835 | 7465 | 1870 | 2/5 |
| | 7000 | 3020 | 7965 | 2055 | 2/5 |
| | 7500 | 3180 | 8465 | 2215 | 2/5 |
| | 8000 | 3350 | 8965 | 2385 | 2/5 |
| | 8500 | 3580 | 9465 | 2615 | 2/5 |
| | 9000 | 3800 | 9965 | 2835 | 2/5 |
| | 9500 | 3970 | 10465 | 3005 | 2/5 |
| | 10000 | 4100 | 10965 | 3135 | 2/5 |
| | 10500 | 4300 | 11465 | 3335 | 2/5 |
| | 11000 | 4500 | 11965 | 3535 | 2/5 |
| | 11500 | 4800 | 12465 | 3835 | 2/5 |
| 12000* | 5000 | 12965 | 4035 | 2/5 | |
| 12500* | 5300 | 13465 | 4335 | 2/5 | |
| 13000* | 5600 | 13965 | 4635 | 2/5 | |

* When you choose the mast, the dimensions of the truck will be affected. Please refer to the performance parameter table for details.

1.4t Residual Load Capacity Chart

| Capacity(kg) | Load center distance(mm) | | | | | | | |
|---------------------|--------------------------|------|------|------|------|------|------|-----|
| | 600 | 700 | 800 | 900 | 1000 | 1100 | 1200 | |
| Lifting height (mm) | ≤6500 | 1400 | 1210 | 1070 | 920 | 780 | 660 | 550 |
| | 7000 | 1350 | 1170 | 1030 | 880 | 750 | 630 | 520 |
| | 7500 | 1250 | 1080 | 950 | 810 | 680 | 570 | 460 |
| | 8000 | 1200 | 1030 | 910 | 770 | 650 | 530 | 430 |
| | 8500 | 1150 | 990 | 870 | 730 | 610 | 500 | 400 |
| | 9000 | 1050 | 900 | 790 | 660 | 550 | 440 | 350 |
| | 9500 | 950 | 810 | 710 | 590 | 480 | 380 | 290 |
| | 10000 | 850 | 720 | 630 | 510 | 410 | 320 | 230 |
| | 10500 | 700 | 590 | 510 | 400 | 310 | 230 | 150 |
| | 11000 | 400 | 320 | 270 | 190 | 110 | 40 | 0 |

1.6t Residual Load Capacity Chart

| Capacity(kg) | Load center distance(mm) | | | | | | | |
|---------------------|--------------------------|------|------|------|------|------|------|-----|
| | 600 | 700 | 800 | 900 | 1000 | 1100 | 1200 | |
| Lifting height (mm) | ≤6500 | 1600 | 1390 | 1230 | 1060 | 920 | 780 | 660 |
| | 7000 | 1550 | 1340 | 1190 | 1030 | 880 | 750 | 640 |
| | 7500 | 1450 | 1250 | 1110 | 950 | 810 | 690 | 570 |
| | 8000 | 1400 | 1210 | 1070 | 910 | 780 | 660 | 550 |
| | 8500 | 1350 | 1170 | 1030 | 880 | 750 | 630 | 520 |
| | 9000 | 1250 | 1080 | 950 | 810 | 680 | 570 | 460 |
| | 9500 | 1150 | 990 | 870 | 730 | 610 | 500 | 400 |
| | 10000 | 1050 | 900 | 790 | 660 | 550 | 440 | 350 |
| | 10500 | 900 | 770 | 670 | 560 | 450 | 350 | 260 |
| | 11000 | 600 | 500 | 430 | 330 | 250 | 160 | 90 |

1.8t Residual Load Capacity Chart

| Capacity(kg) | Load center distance(mm) | | | | | | | |
|---------------------|--------------------------|------|------|------|------|------|------|-----|
| | 600 | 700 | 800 | 900 | 1000 | 1100 | 1200 | |
| Lifting height (mm) | ≤6500 | 1800 | 1570 | 1390 | 1210 | 1050 | 900 | 780 |
| | 7000 | 1750 | 1520 | 1350 | 1170 | 1010 | 870 | 750 |
| | 7500 | 1650 | 1430 | 1270 | 1100 | 950 | 810 | 690 |
| | 8000 | 1600 | 1390 | 1230 | 1060 | 910 | 780 | 660 |
| | 8500 | 1550 | 1340 | 1190 | 1020 | 880 | 750 | 630 |
| | 9000 | 1450 | 1250 | 1110 | 950 | 810 | 690 | 570 |
| | 9500 | 1350 | 1170 | 1030 | 880 | 750 | 630 | 520 |
| | 10000 | 1250 | 1080 | 950 | 810 | 680 | 570 | 460 |
| | 10500 | 1100 | 940 | 830 | 700 | 580 | 470 | 370 |
| | 11000 | 800 | 680 | 590 | 480 | 380 | 290 | 200 |
| | 11500 | 600 | 500 | 430 | 330 | 250 | 160 | 90 |

2.0t Residual Load Capacity Chart

| Capacity(kg) | Load center distance(mm) | | | | | | | |
|---------------------|--------------------------|------|------|------|------|------|------|-----|
| | 600 | 700 | 800 | 900 | 1000 | 1100 | 1200 | |
| Lifting height (mm) | ≤6500 | 2000 | 1750 | 1560 | 1360 | 1200 | 1040 | 910 |
| | 7000 | 1950 | 1710 | 1520 | 1330 | 1160 | 1010 | 880 |
| | 7500 | 1850 | 1620 | 1440 | 1250 | 1090 | 950 | 820 |
| | 8000 | 1800 | 1570 | 1400 | 1220 | 1060 | 920 | 790 |
| | 8500 | 1750 | 1530 | 1360 | 1180 | 1030 | 890 | 760 |
| | 9000 | 1650 | 1440 | 1280 | 1110 | 960 | 830 | 700 |
| | 9500 | 1550 | 1350 | 1190 | 1030 | 890 | 760 | 650 |
| | 10000 | 1450 | 1260 | 1110 | 960 | 820 | 700 | 590 |
| | 10500 | 1300 | 1130 | 990 | 850 | 720 | 610 | 500 |
| | 11000 | 1000 | 860 | 750 | 630 | 520 | 420 | 330 |
| | 11500 | 800 | 680 | 590 | 480 | 390 | 290 | 210 |
| 12000 | 750 | 630 | 550 | 450 | 350 | 260 | 180 | |
| 12500 | 650 | 550 | 470 | 370 | 280 | 200 | 120 | |
| 13000 | 500 | 410 | 350 | 260 | 180 | 110 | 40 | |

2.5t Residual Load Capacity Chart

| Capacity(kg) | Load center distance(mm) | | | | | | | |
|---------------------|--------------------------|------|------|------|------|------|------|------|
| | 600 | 700 | 800 | 900 | 1000 | 1100 | 1200 | |
| Lifting height (mm) | ≤6500 | 2500 | 2200 | 1960 | 1730 | 1530 | 1360 | 1200 |
| | 7000 | 2450 | 2150 | 1920 | 1700 | 1500 | 1330 | 1170 |
| | 7500 | 2350 | 2060 | 1840 | 1620 | 1430 | 1260 | 1110 |
| | 8000 | 2300 | 2020 | 1800 | 1590 | 1400 | 1230 | 1080 |
| | 8500 | 2250 | 1970 | 1760 | 1550 | 1360 | 1200 | 1050 |
| | 9000 | 2150 | 1880 | 1680 | 1480 | 1300 | 1140 | 990 |
| | 9500 | 2050 | 1800 | 1600 | 1400 | 1230 | 1080 | 940 |
| | 10000 | 1950 | 1710 | 1520 | 1330 | 1160 | 1010 | 880 |
| | 10500 | 1800 | 1570 | 1400 | 1220 | 1060 | 920 | 790 |
| | 11000 | 1500 | 1300 | 1150 | 1000 | 860 | 730 | 620 |
| | 11500 | 1300 | 1130 | 990 | 850 | 720 | 610 | 500 |
| 12000 | 1250 | 1080 | 950 | 810 | 690 | 580 | 470 | |
| 12500 | 1150 | 990 | 870 | 740 | 620 | 510 | 410 | |
| 13000 | 1000 | 860 | 750 | 630 | 520 | 420 | 330 | |

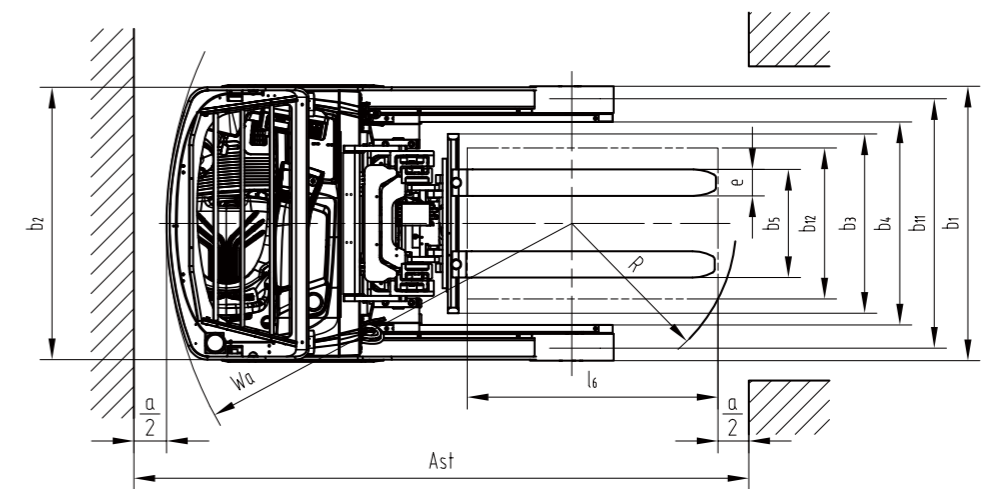
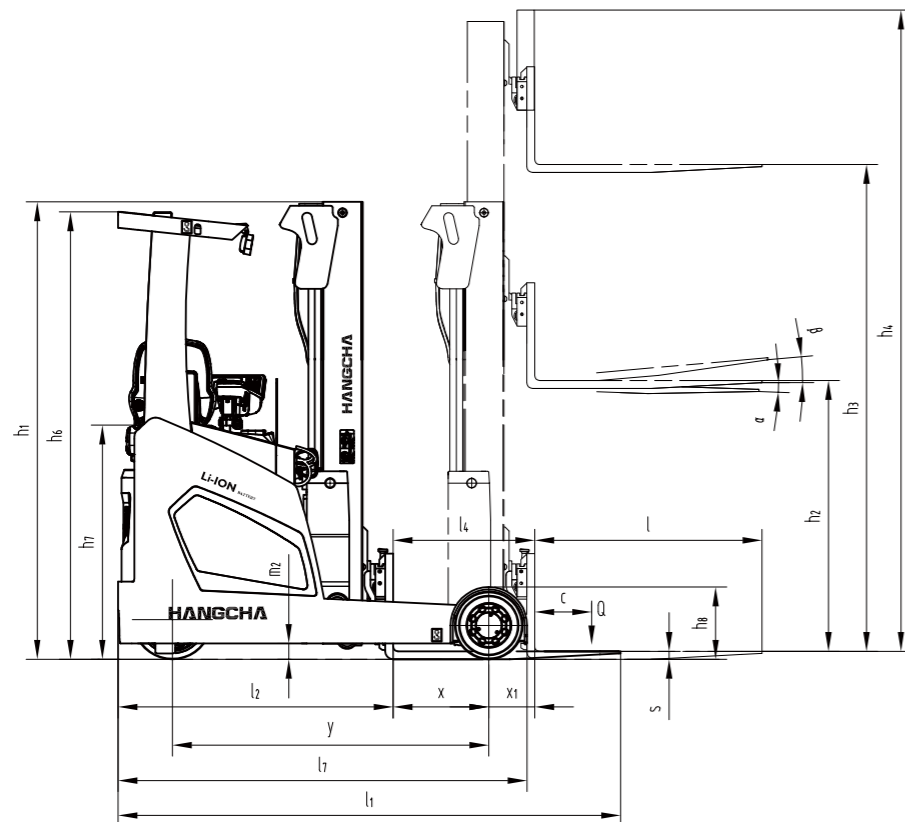

$$A_{st} = W_a + R + a = W_a + \sqrt{(l_6 - x)^2 + \left(\frac{b_{12}}{2}\right)^2} + a$$