



Heavy Lift Forklifts PTYLTD. CO., LTD.

Factory site: 826 Mountain Road
Bayswater Victoria 3153

Tel: 0397624965 +

sales@heavyliftforklifts.com.au
www.heavyliftforklifts.com.au



Follow us on
Facebook



Follow us on
YouTube



Follow us on
WeChat



Download "Hangcha
Forklift" App



ISO14001
ISO14001:2015



ISO9001
ISO9001:2015



HANGCHA trucks conform
to the European Safety
Requirements.

2023 VERSION / COPYRIGHT 2023/02

HANGCHA GROUP CO., LTD. reserves the right to make any changes without notice concerning colors, equipment, or specifications detailed in this brochure, or to discontinue individual models. The colors of trucks, delivered may differ slightly from those in brochures.

XC Series 4-W Electric Forklift Truck With Lithium Iron-Phosphate

with capacity of 1,500 to 3,500kg



The World of Hangcha
SINCE 1956



INNOVATIVE SOLUTIONS NEW POWER NOW

The XC series new energy electric forklifts, covering range from 1.5t to 3.5t, is a series of products with new chassis launched by HANGCHA.

Innovative, reliable lithium-ion technology, which are developed jointly by HANGCHA and CATL. Battery cells and modules are from CATL, with reliable quality, exclusively for HANGCHA.

Rapid charging and opportunity charging ensure continuous availability of trucks.

Lightweight design, flexible, high level of energy efficiency, maintenance-free, long service life.



High capacity CATL battery packs

Integrated Battery Management System (BMS) continually monitors energy management and ensures reliable operation. HANGCHA provides Li-Ion battery with 5 years or 10000 hours warranty.

		Battery capacity (kW·h)
Pack1	1.5 - 1.8t: standard	80V*202Ah, 16.16Kwh
Pack2	1.5 - 1.8t: optional	80V*271Ah, 21.68Kwh
Pack3	2.0 - 2.5t: standard	80V*271Ah, 21.68Kwh
Pack4	2.0 - 2.5t: optional	80V*404Ah, 32.32Kwh
Pack5	3.0 - 3.5t: standard	80V*404Ah, 32.32Kwh
Pack6	3.0 - 3.5t: optional	80V*542Ah, 43.36Kwh

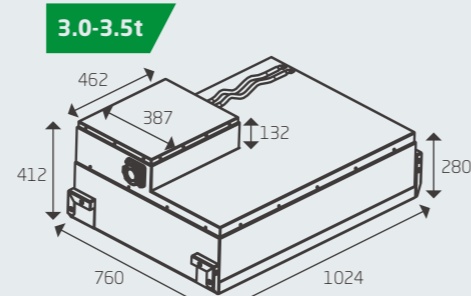
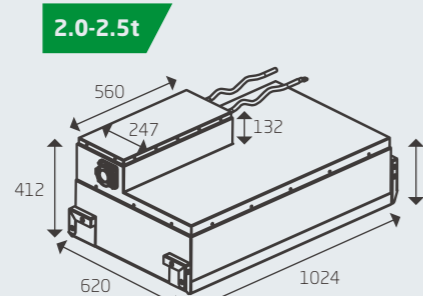
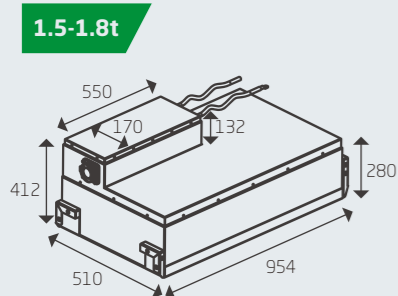

Excellent Ergonomic Design



- / The truck has a large operating space more than **50%** larger than the traditional electric truck.
- / The dashboard in the driver's cab is placed overhead and can be seen when the driver lifts her/his head, and the function buttons can be pressed easily.
- / For the optional integrated fingertip control system, the combined operating armrest integrates the emergency cut-off, horn and quadruple thumb switches, etc., is electrically controlled through the CAN bus and is highly reliable.
- / The enlarged brake pedal and appropriate regenerative braking function can effectively reduce the driver's fatigue.



Advantages



The rear axle is provided with a flexible suspension system (for standard configuration and automatic deceleration at turns improve the driver's comfort).

The high-frequency MOSFET integrated controller ensures smooth and accurate driving and lifting control, and has excellent speed regulation performance, good performance of electronic control matching the motor, functions of regenerative braking, reverse braking and anti-sliding on ramps, etc., and high safety and reliability.

The ultra-high power AC traction motor has a bridge structure. An ultra-high power AC pump motor is used. The system has high efficiency, complete protection functions, built-in speed and temperature sensors, and greatly improved reliability and life.

**RELIABLE
TRUCKS**

**HEAVY LIFT
FORKLIFTS**



**5 YEARS
WARRANTY**

Easy operations and maintenance

Internal Components Protected with Fully-sealed Hood, controllers, motors electrical components, etc. are sealed from dust and water.

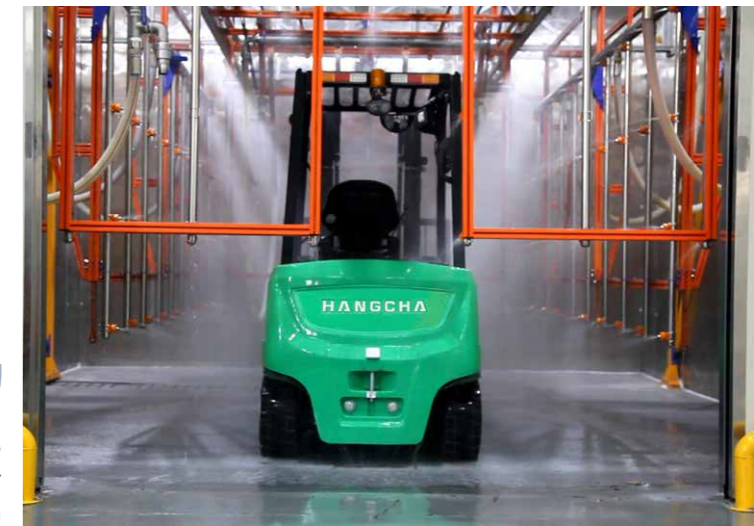

IPX4 water resistance rating, suitable for outdoor operation



The hood can be opened at a large angle facilitating the maintenance.



**HEAVY LIFT
FORKLIFTS**

Safety

The optional OPS system can disable the lowering when the driver leaves the seat and enable high safety.

The standard configuration provides soft landing system. In addition, an optional lift buffering system is provided to protect the goods from falling and damaging the ground.

The handbrake can be optionally equipped with an alarm buzzer to prompt the driver to pull up the handbrake before leaving the truck.



Three horn buttons are provided, which are respectively on the driver's steering wheel, thumb switch equipped armrest (optional) and reverse armrest (optional), for alerting and protecting the surrounding people.



A PIN code should be provided before entering the system. 99 sets of PIN codes are available for the administrator. The truck is highly secured and irrelevant personnel cannot start the truck.



IP67 Protection Rating



Quick charge < 2.0h,
Working time > 9.0h

Comfort

Owing to the low center of gravity and good stability, the driver feels comfortable during turning.

The ergonomically designed adjustable steering wheel makes the driver feel good. The seat can be adjusted back and forth by 210mm. The operator can choose the best driving position.

New designed mast increases the wide view by 15%.

With friendly human-computer interfaces, the 4.33" True Color Screen instruments have good visibility and clear readings.

Silence, no pollution, energy saving and other advantages meet the environmental protection requirements.



Grammer fingertip (Optional)



Main Accessories

The main electrical components such as the controller, contactor, power plug, emergency cut-off switch, dashboard, accelerator, are all products of well-known world brands.

The emergency cut-off switch equipped for the standard configuration complies with EU regulations.

The truck has passed the CE certification.



Options

- / Lithium packs that can be replaced quickly
- / Pin code or card
- / Super elastic tyre
- / Marked solid tyre
- / Left and right rear view mirrors
- / Backup camera
- / Front/rear blue lights
- / Rear working lights
- / Charger (Titan or Schneider)
- / Reverse armrest
- / Hood with a key lock
- / OPS system
- / Lift buffering system
- / Multi way valves
- / Integrated fingertip control system
- / Widened / heightened load backrest
- / Widened fork carriage
- / Other length forks
- / Full free duplex mast
- / Full free triplex mast
- / Sideshifter
- / Other attachments
- / Grammer MSG531 suspension seat

Standard specification

- / Battery pack side roll out
- / Lithium packs with low temperature electric heating systems
- / High-power AC drive motor
- / High-power AC pump motor
- / Low noise gear pump
- / Multi-function color screen instrument cluster
- / Large integral rubber pedal pad
- / LED combination headlights, LED rear combination taillights
- / Stamped iron hood
- / Automatic deceleration at turns
- / Soft landing system
- / SPE power selection
- / Charging muzzle meeting national standards
- / Electronic cooling fan
- / Emergency cut-off switch
- / Reversing buzzer
- / Traction pin
- / Folder
- / Load sensing steering system
- / Duplex mast
- / Tilt cylinder jacket

1.5t XC series mast specification

Type	Model	Lifting height	Overall height			Free lifting height		Tilting range		Load capacity	
			Lowered overall height	Extended height		Without backrest	With backrest	FWD	BWD	Load center@500mm	
				Without backrest	With backrest					Single Tire	Double Tire
				mm	mm					1.5t	1.5t
Duplex wide view mast	XPD15M200	2000	1475	2538	2955	135	135	6/12	6/12	1500	1500
	XPD15M250	2500	1725	3038	3455	135	135	6/12	6/12	1500	1500
	XPD15M270	2700	1825	3238	3655	135	135	6/12	6/12	1500	1500
	XPD15M300	3000	1975	3538	3955	135	135	6/12	6/12	1500	1500
	XPD15M330	3300	2125	3838	4255	135	135	6/12	6/12	1500	1500
	XPD15M350	3500	2225	4038	4455	135	135	6/12	6/12	1500	1500
	XPD15M360	3600	2325	4138	4555	135	135	6/12	6/12	1500	1500
	XPD15M370	3700	2375	4238	4655	135	135	6/12	6/12	1500	1500
	XPD15M400	4000	2575	4538	4955	135	135	6/12	6/12	1500	1500
	XPD15M430	4300	2725	4838	5255	135	135	6/6	6/6	1500	1500
	XPD15M450	4500	2825	5038	5455	135	135	6/6	6/6	1500	1500
	XPD15M480	4800	2975	5338	5755	135	135	6/6	6/6	1400	1500
	XPD15M500	5000	3075	5538	5955	135	135	6/6	6/6	1350	1400
	XPD15U200	2000	1490	2559	2945	931	545	6/6	6/6	1500	1500
	XPD15U250	2500	1740	3059	3445	1181	795	6/12	6/12	1500	1500
XPD15U270	2700	1840	3259	3645	1281	895	6/12	6/12	1500	1500	
XPD15U300	3000	1990	3559	3945	1431	1045	6/12	6/12	1500	1500	
XPD15U330	3300	2140	3859	4245	1581	1195	6/12	6/12	1500	1500	
XPD15U350	3500	2240	4059	4445	1681	1295	6/12	6/12	1500	1500	
XPD15U360	3600	2290	4159	4545	1731	1345	6/12	6/12	1500	1500	
XPD15U370	3700	2340	4259	4645	1781	1395	6/12	6/12	1500	1500	
XPD15U400	4000	2540	4559	4945	1981	1595	6/12	6/12	1500	1500	
Triplex full-free mast	XPD15N430	4300	2040	4869	5255	1481	1095	6/6	6/6	1500	1500
	XPD15N450	4500	2090	5069	5455	1531	1145	6/6	6/6	1500	1500
	XPD15N470	4700	2190	5269	5655	1631	1245	6/6	6/6	1400	1500
	XPD15N480	4800	2240	5369	5755	1681	1295	6/6	6/6	1400	1500
	XPD15N500	5000	2340	5569	5955	1781	1395	6/6	6/6	1400	1450
	XPD15N550	5500	2540	6069	6455	1981	1595	3/6	3/6	1250	1350
XPD15N600	6000	2790	6600	6955	2200	1845	3/6	3/6	1100	1150	

With sideshifter minus 200Kg,with integral sideshifter minus 150kg.

2.0~2.5t XC series mast specification

Type	Model	Lifting height	Lowered overall height	Overall height		Free lifting height		Tilting range		Capacity (Mast vertical to ground)			
				Without backrest	With backrest	Without backrest	With backrest	FWD	BWD	Load center@500mm			
										Single Tire		Double Tire	
										2.0t	2.5t	2.0t	2.5t
Duplex wide view mast	XPD25M200	2000	1501	2626	3046	140	140	6	6	2000	2500	2000	2500
	XPD25M250	2500	1751	3126	3546	140	140	6	12	2000	2500	2000	2500
	XPD25M270	2700	1851	3326	3746	140	140	6	12	2000	2500	2000	2500
	XPD25M300	3000	2001	3626	4046	140	140	6	12	2000	2500	2000	2500
	XPD25M330	3300	2151	3926	4346	140	140	6	12	2000	2500	2000	2500
	XPD25M350	3500	2251	4126	4546	140	140	6	12	2000	2500	2000	2500
	XPD25M360	3600	2351	4226	4646	140	140	6	12	2000	2500	2000	2500
	XPD25M370	3700	2401	4326	4746	140	140	6	12	2000	2500	2000	2500
	XPD25M400	4000	2601	4626	5046	140	140	6	12	2000	2500	2000	2500
	XPD25M430	4300	2751	4926	5346	140	140	6	6	2000	2500	2000	2500
	XPD25M450	4500	2851	5126	5546	140	140	6	6	2000	2450	2000	2500
	XPD25M470	4700	2951	5326	5746	140	140	6	6	1950	2350	2000	2450
	XPD25M480	4800	3001	5426	5846	140	140	6	6	1950	2350	2000	2450
	XPD25M500	5000	3101	5626	6046	140	140	6	6	1850	2300	1950	2350
	XPD25M550	5500	3351	6126	6546	140	140	3	6	1750	2150	1900	2200
XPD25M600	6000	3601	6626	7046	140	140	3	6	1550	1900	1800	2000	
Duplex full-free mast	XPD25U200	2000	1516	2749	3046	842	470	6	6	2000	2500	2000	2500
	XPD25U250	2500	1766	3173.5	3546	1092	720	6	12	2000	2500	2000	2500
	XPD25U270	2700	1866	3373.5	3746	1192	820	6	12	2000	2500	2000	2500
	XPD25U300	3000	2016	3673.5	4046	1342	970	6	12	2000	2500	2000	2500
	XPD25U330	3300	2166	3973.5	4346	1492	1120	6	12	2000	2500	2000	2500
	XPD25U350	3500	2266	4173.5	4546	1592	1220	6	12	2000	2500	2000	2500
	XPD25U360	3600	2316	4273.5	4646	1642	1270	6	12	2000	2500	2000	2500
	XPD25U370	3700	2366	4373.5	4746	1692	1320	6	12	2000	2500	2000	2500
	XPD25N400	4000	1966	4670.5	5046	1195	920	6	6	2000	2500	2000	2500
	XPD25N430	4300	2066	4970.5	5346	1295	1020	6	6	2000	2450	2000	2500
	XPD25N450	4500	2116	5170.5	5546	1345	1070	6	6	2000	2350	2000	2450
	XPD25N470	4700	2216	5370.5	5746	1445	1170	6	6	1950	2250	2000	2350
	XPD25N480	4800	2266	5470.5	5846	1495	1220	6	6	1950	2250	2000	2350
	XPD25N500	5000	2366	5670.5	6046	1595	1320	6	6	1850	2100	1950	2250
	XPD25N550	5500	2566	6170.5	6546	1795	1520	3	6	1750	2050	1900	2100
XPD25N600	6000	2816	6670.5	7046	2045	1770	3	6	1550	1850	1800	1950	
XPD25N650	6500	3016	7170.5	7546	2245	1970	3	6	/	/	1550	1800	
XPD25N700	7000	3266	7766	8046	2695	2220	3	6	/	/	1150	1450	

With sideshifter minus 200Kg,with integral sideshifter minus 150kg.

1.8t XC series mast specification

Type	Model	Lifting height	Overall height			Free lifting height		Tilting range		Load capacity	
			Lowered overall height	Extended height		Without backrest	With backrest	FWD	BWD	Load center@500mm	
				Without backrest	With backrest					Single Tire	Double Tire
				mm	mm					1.8t	1.8t
Duplex wide view mast	XPD18M200	2000	1475	2648	2955	135	135	6/12	6/12	1800	1800
	XPD18M250	2500	1725	3148	3455	135	135	6/12	6/12	1800	1800
	XPD18M270	2700	1825	3348	3655	135	135	6/12	6/12	1800	1800
	XPD18M300	3000	1975	3648	3955	135	135	6/12	6/12	1800	1800
	XPD18M330	3300	2125	3948	4255	135	135	6/12	6/12	1800	1800
	XPD18M350	3500	2225	4148	4455	135	135	6/12	6/12	1800	1800
	XPD18M360	3600	2325	4248	4555	135	135	6/12	6/12	1800	1800
	XPD18M370	3700	2375	4348	4655	135	135	6/12	6/12	1800	1800
	XPD18M400	4000	2575	4648	4955	135	135	6/12	6/12	1800	1800
	XPD18M430	4300	2725	4948	5255	135	135	6/6	6/6	1700	1750
	XPD18M450	4500	2825	5148	5455	135	135	6/6	6/6	1650	1700
	XPD18M480	4800	2975	5448	5755	135	135	6/6	6/6	1600	1650
	XPD18M500	5000	3075	5648	5955	135	135	6/6	6/6	1550	1600
	XPD18U200	2000	1490	2669	2945	821	545	6/6	6/6	1800	1800
	XPD18U250	2500	1740	3169	3445	1071	795	6/12	6/12	1800	1800
XPD18U270	2700	1840	3369	3645	1171	895	6/12	6/12	1800	1800	
XPD18U300	3000	1990	3669	3945	1321	1045	6/12	6/12	1800	1800	
XPD18U330	3300	2140	3969	4245	1471	1195	6/12	6/12	1800	1800	
XPD18U350	3500	2240	4169	4445	1571	1295	6/12	6/12	1800	1800	
XPD18U360	3600	2290	4269	4545	1621	1345	6/12	6/12	1800	1800	
XPD18U370	3700	2340	4369	4645	1671	1395	6/12	6/12	1800	1800	
XPD18U400	4000	2540	4669	4945	1871	1595	6/12	6/12	1800	1800	
Triplex full-free mast	XPD18N430	4300	2040	4979	5255	1371	1095	6/6	6/6	1650	1800
	XPD18N450	4500	2090	5179	5455	1421	1145	6/6	6/6	1650	1750
	XPD18N470	4700	2190	5379	5655	1521	1245	6/6	6/6	1600	1650
	XPD18N480	4800	2240	5479	5755	1571	1295	6/6	6/6	1600	1650
	XPD18N500	5000	2340	5							

XC Series 1.5~3.5t Electric Forklift



Distinguishing mark	HANGCHA GROUP CO.,LTD.							
		CPD15-XD4-SI16	CPD18-XD4-SI16	CPD20-XD4-SI26	CPD25-XD4-SI26	CPD30-XD4-SI26	CPD35-XD4-SI26	
1.1	Manufacturer							
1.2	Manufacturers type designation							
1.3	Drive: electric (battery or mains), diesel, petrol, fuel gas	Electric	Electric	Electric	Electric	Electric	Electric	
1.4	Operator type: hand, pedestrian, standing, seated, order-picker	Seated	Seated	Seated	Seated	Seated	Seated	
1.5	Load capacity/rated load	Q (kg)	1500	1800	2000	2500	3000	3500
1.6	Load centre distance	c (mm)	500	500	500	500	500	500
1.8	Load distance, centre of drive axle to fork	x (mm)	405	410	444	444	482	482
1.9	Wheelbase	y (mm)	1380	1380	1520	1520	1650	1650
2.1	Service Weight	kg	2850	3080	3620	3920	4740	5080
2.2	Axle loading, laden front/rear	kg	3760/590	4255/625	5040/680	5820/700	6745/1095	7800/880
2.3	Axle loading, unladen front/rear	kg	1220/1630	1280/1800	1620/2000	1670/2250	2010/2730	2100/2980
3.1	Tyres: solid rubber, superelastic, pneumatic, polyurethane		Pneumatic	Pneumatic	Pneumatic	Pneumatic	Pneumatic	Super elastic
3.2	Tyre size, front		6.00-9NHS-10PR	21*8-9NHS-16PR	23*9-10	23*9-10	23*9-10	23*10-12
3.3	Tyre size, rear		5.00-8NHS-10PR	5.00-8NHS-10PR	18*7-8	18*7-8	18*7-8	200/50-10
3.5	Wheels, number front rear (x = driven wheels)		2x/2	2x/2	2x/2	2x/2	2x/2	2x/2
3.6	Tread, front	b10 (mm)	888	938	1068	1068	1068	1068
3.7	Tread, rear	b11 (mm)	915.5	915.5	960	960	960	960
4.1	Tilt of mast/fork carriage forward/backward	$\alpha/\beta(^{\circ})$	6/12	6/12	6/12	6/12	6/12	6/12
4.2	Height, mast lowered	h1 (mm)	1975	1975	2001	2001	2151	2151
4.3	Free lift	h2 (mm)	135	135	140	140	145	145
4.4	Lift	h3 (mm)	3000	3000	3000	3000	3000	3000
4.5	Height, mast extended	h4 (mm)	3955	3955	4040	4040	4135	4135
4.7	Height of overhead guard STD.	h6 (mm)	2080	2080	2100	2100	2100	2100
4.8	Seat height/stand height	h7 (mm)	1100	1100	1120	1120	1120	1120
4.12	Coupling height	h10 (mm)	420	420	430	430	430	430
4.19	Overall length	l1 (mm)	3056	3061	3370	3370	3550	3550
4.20	Length to face of forks	l2 (mm)	2136	2141	2300	2300	2480	2480
4.21	Overall width	b1 (mm)	1120	1138	1252	1252	1252	1298
4.22	Fork dimensions	s/e/l (mm)	35/100/920	35/100/920	40/122/1070	40/122/1070	45/122/1070	50/122/1070
4.23	Fork carriage DIN 15 173 --- ISO 2328, class/type A,B		ISO2328 2A	ISO2328 2A	ISO2328 2A	ISO2328 2A	ISO2328 3A	ISO2328 3A
4.24	Fork-carriage width	b3 (mm)	1000	1000	1038	1038	1100	1100
4.25	Distance between fork-arms	b5 (mm)	240/1000	240/1000	290/1100	290/1100	290/1100	290/1100
4.31	Ground clearance, laden, below mast	m1 (mm)	95	95	100	100	100	100
4.32	Ground clearance, centre of wheelbase	m2 (mm)	90	90	125	125	125	125
4.34.1	Aisle width for pallets 1000 x 1200 crossways	Ast (mm)	3555	3560	3734	3734	3955	3955
4.34.2	Aisle width for pallets 800 x 1200 Lengthways	Ast (mm)	3755	3760	3934	3934	4155	4155
4.35	Turning radius	Wa (mm)	1950	1950	2090	2090	2270	2270
4.36	Internal turning radius	b13 (mm)	620	620	655	655	730	730
5.1	Travel speed, laden/unladen	km/h	16/17	16/17	18/19	18/19	18/19	18/19
5.2	Lift speed, laden/unladen	m/s	0.430/0.460	0.420/0.460	0.450/0.560	0.430/0.560	0.390/0.540	0.370/0.540
5.3	Lowering speed, laden/unladen	m/s	0.520/0.480	0.520/0.480	0.450/0.420	0.470/0.420	0.450/0.420	0.470/0.420
5.5	Drawbar pull, laden/unladen	N	9000/10000	9500/11000	13000/14000	17000/18000	20000/21000	20500/21000
5.6	Max. Drawbar pull, laden/unladen	N	11000	12000	15000	19000	22000	23000
5.7	Gradeability, laden/unladen	%	20/20	20/20	20/20	20/20	20/20	20/20
5.8	Max. gradeability, laden/unladen	%	20/20	20/20	20/20	20/20	20/20	20/20
5.9	Acceleration time, laden/unladen (0-10m)	s	4.8/4.4	4.8/4.4	4.0/3.9	4.3/4.2	4.9/4.7	5.0/4.8
5.10	Service brake		Hydraulic	Hydraulic	Hydraulic	Hydraulic	Hydraulic	Hydraulic
5.11	Parking brake		Mechanical	Mechanical	Mechanical	Mechanical	Mechanical	Mechanical
6.1	Drive motor rating S2 60 min	kW	9AC	9AC	16.6AC	16.6AC	16.6AC	16.6AC
6.2	Lift motor rating at S3 15%	kW	16AC	16AC	25.5AC	25.5 AC	25.5AC	25.5AC
6.3	Battery voltage, Std.	V/Ah	80/202	80/202	80/271	80/271	80/404	80/404
	Battery voltage, Opt.	V/Ah	80/271	80/271	80/404	80/404	80/542	80/542
6.5	Min. battery weight	kg	160	160	220	220	320	320
	Max. battery weight	kg	195	195	280	280	380	380
8.1	Type of drive control		MOSFET/AC	MOSFET/AC	MOSFET/AC	MOSFET/AC	MOSFET/AC	MOSFET/AC
9.1	Manufacturer		INMOTION	INMOTION	INMOTION	INMOTION	INMOTION	INMOTION
10.1	Operating pressure for attachments	bar	145	145	175	175	175	175
10.2	Oil volume for attachments	l/min	65	65	65	65	65	65
10.3	Hydraulic Tank - capacity (drain & refill)	liter	25	25	28	28	28	28
10.7	Sound level at the driver's ear according to EN / DIN 12 053	dB (A)	75	75	75	75	75	75
10.8	Towing coupling, type DIN		Φ25 Pin	Φ25 Pin	Φ25 Pin	Φ25 Pin	Φ25 Pin	Φ25 Pin

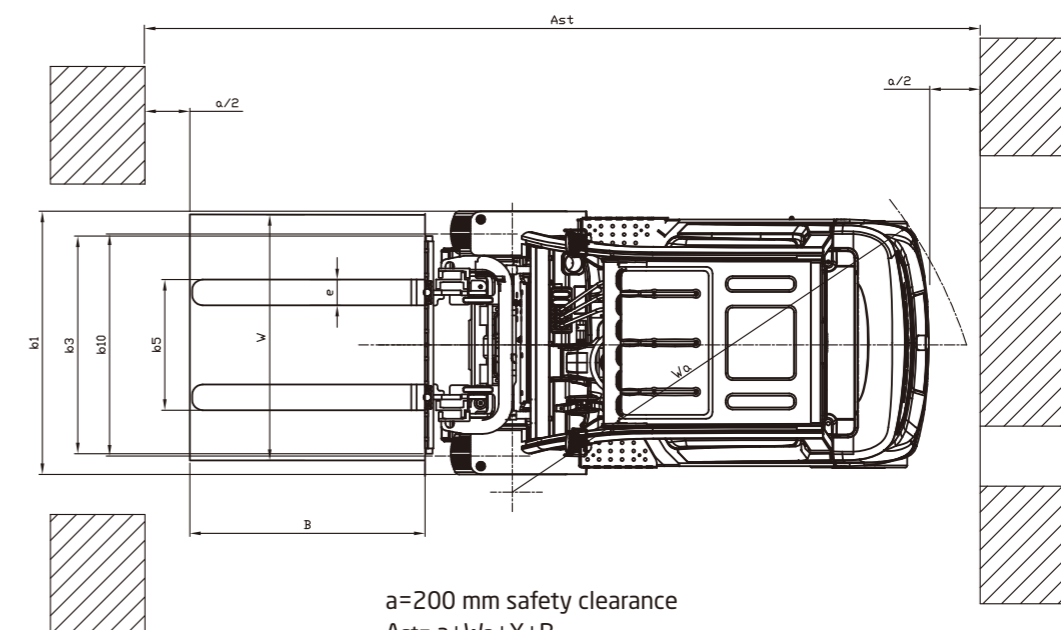
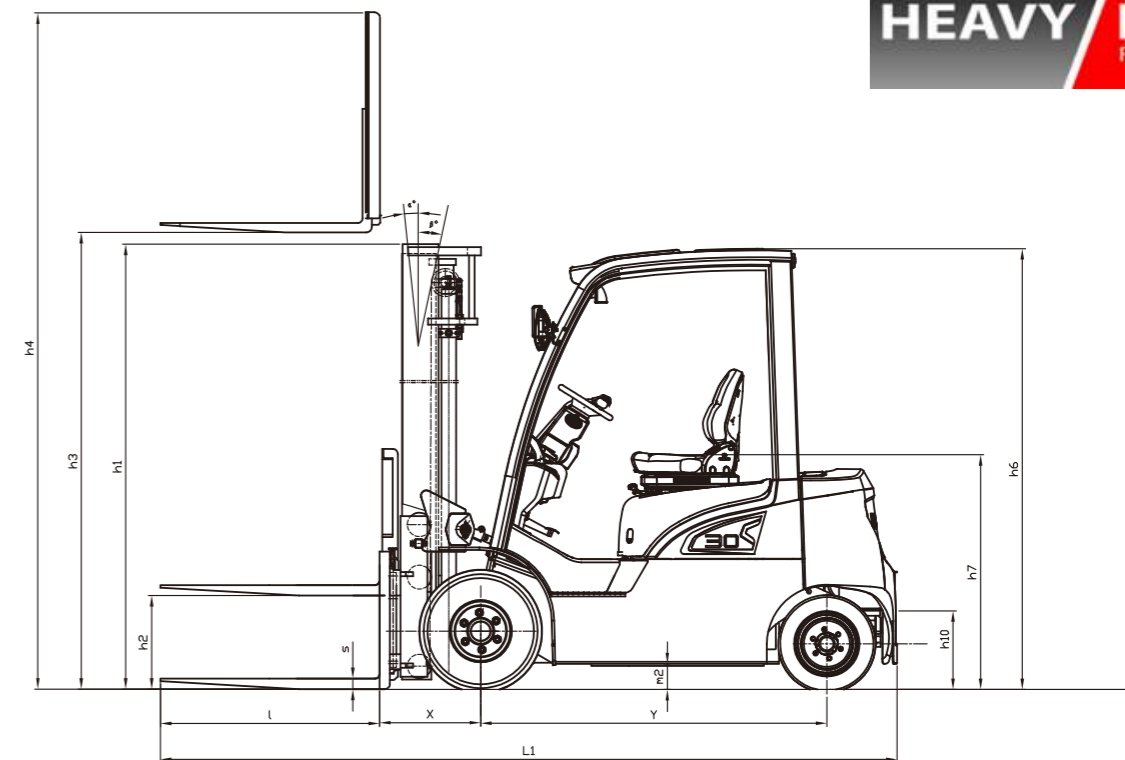

a=200 mm safety clearance
Ast= a+Wa+X+B

