



**Heavy Lift Forklifts**  
**826 Mountain Highway Bayswater Vic**  
**3153 Australia**

**Tel: 03 9762 4975**

**sales@heavyliftforklifts.com.au**



Follow us on  
Facebook



Follow us on  
YouTube



Follow us on  
WeChat



Download "Hangcha  
Forklift" App



ISO14001  
ISO14001:2015



ISO9001  
ISO9001:2015



HANGCHA trucks conform  
to the European Safety  
Requirements.

2023 VERSION 2/COPYRIGHT 2023/06

HANGCHA GROUP CO., LTD. reserves the right to make any changes without notice concerning colors, equipment, or specifications detailed in this brochure, or to discontinue individual models. The colors of trucks, delivered may differ slightly from those in brochures.



## XF Series Diesel Counterbalanced Trucks

with capacities of 8,000 to 12,000kg

*The World of Hangcha*



# HANGCHA be with you at every stage

Efficient, reliable solutions for your demands

## STAGE V

With Hangcha you can meet all Stage V emissions standards which provides customer demands for value, innovation and performance. The technologies include ,TCI+CR+EGR+DOC+DPF+SCR. Designed and optimised to every engine model, our forklift truck maximises efficiency and reliability.



Simple/  
Solid/  
Smart

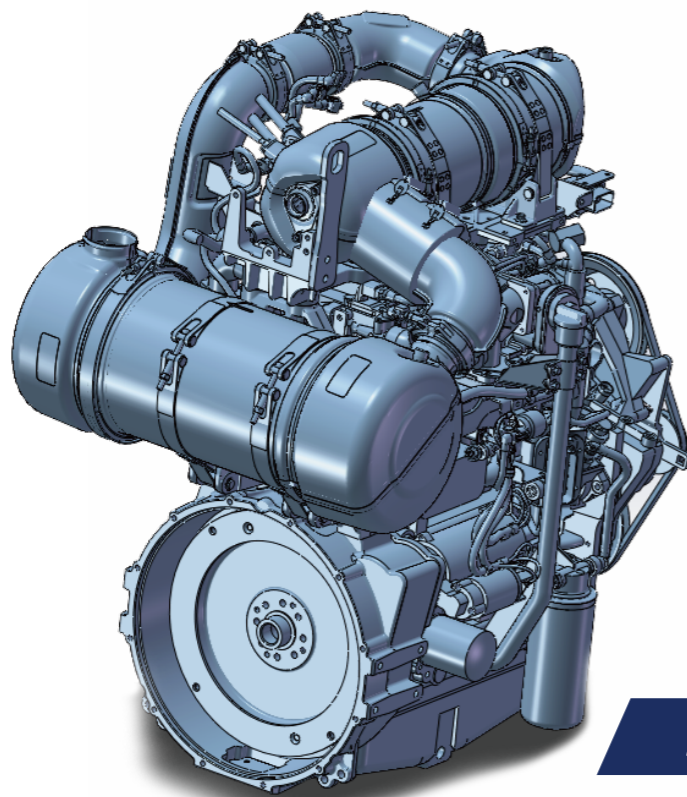

**DEUTZ**



Interactive instrument: The instrument adopts LCD display with four interactive buttons, and has one CAN bus communication function. The communication protocol is compatible with CANopen and SAE J1939 standards.



### HANGCHA Forklift with StageV

No.	Capacity	Series	Manufacturer	Engine	Drive power	Model	Emission Std.	Transmission	Power (kw/rpm)	Service brake
1	8-10t	XF	DEUTZ	TCD3.6 L4	Diesel	CPCD80/100-XW96G	Stage V	ZF	85/2200	Hydraulic
2	12t	XF	DEUTZ	TCD3.6 L4	Diesel	CPCD120-XXW96	Stage V	TCM	85/2200	Hydraulic
3	8-10t	XF	Cummins	F3.8	Diesel	CPCD80/100-XH16B	Stage V/T4f	Okamura	90/2200	Hydraulic
4	8-10t	XF	Yuchai	YCA05115-S500	Diesel	CPCD80/100-XH15B	Stage V	Okamura	85/2200	Hydraulic

Note: Stage V applied for European Union also including Israel and Turkey



## Comfortable Operation

*In developing the new XF 8-12t series, comfort and easy operation is always considered, for example, improved vibrating levels, compound engine damper and full floating seat and cabin are applied.*

*Comfortable also contribute to increased productivity.*

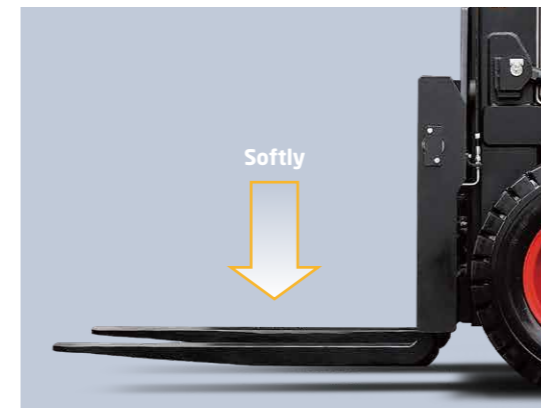
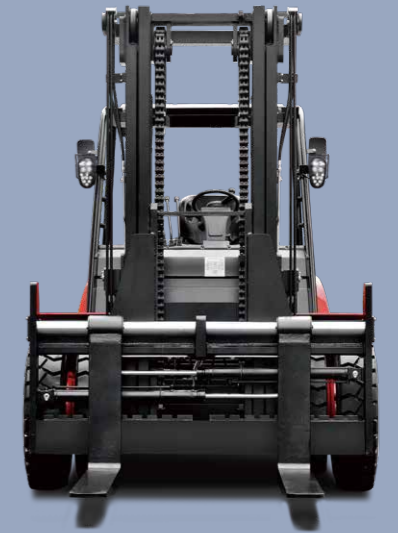

In addition to the soft landing system, the soft lifting system is adopted (front lifting cylinders of triplex mast and full free duplex mast), as a result, the noise and shock of the mast significantly decreases.



The extra foot space is provided to reduce operator fatigue significantly. The new wide-open, non-slip step makes getting in and out easy and safe.

The optional Electro-hydraulic proportional control system contributes more sensitive and precise load handling. The easy-to-operate levers provide total load handling operation. An armrest is provided to reduce fatigue.

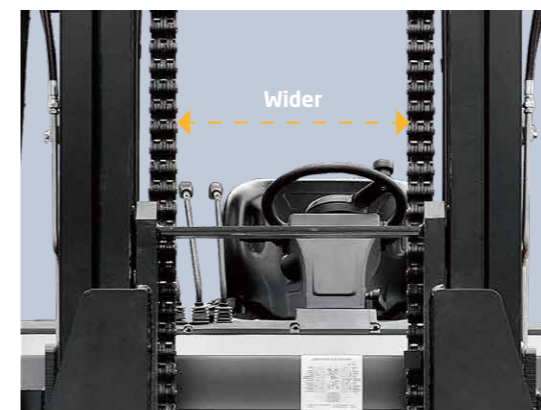

The new design mast provides broad forward visibility due to outside located hydraulic pipes of fork positioner.



## Environmental Friendliness

Environmentally friendly material, low exhaust emission, and low noise level, all these are considered at the beginning of the product development.

Special developed engine is applied for optimum balance of power and superior environmental performance. All diesel engines are in compliance with EU stage-III control regulation.

The environment friendly materials, such as non-asbestos brake shoe and new type sealing gasket, are adopted entirely to meet environmental safety.

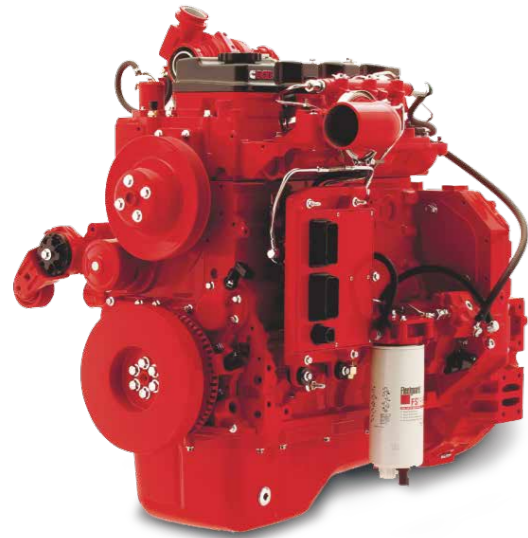

The applied optimized exhaust muffler, intake muffler and the noise shield technologies are reduced 3dB at the driver's ear noise level.

## Productivity

Thanks to the series technological innovations, the efficiency of the truck is improved, the energy consumption is reduced.



By optimizing transmission design, the power train provides higher efficiency, and the Max. driving speed is increased **20%**

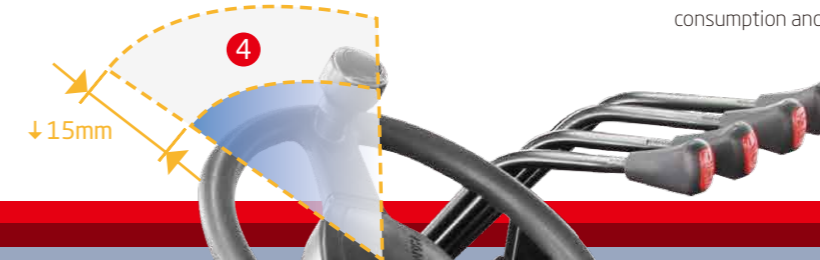

## Comfortable Operation

1. The new, relocated easy-to-see LCD meter lets the operator check on all aspects of operational status at a glance.
2. The new automobile-style light/turn-signal lever and forward-reverse lever are ergonomically designed and arranged to improve comfort and productivity.
3. Only 90N parking brake force is required.
4. The small diameter steering wheel with tilt adjustment provides the ideal operating position. The superior responsiveness of the steering wheel optimizes maneuverability even in narrow spaces.
5. The automobile-style suspended pedals provide more ergonomic operation.



The new efficiency LED lighting system and new type reflector reduce energy consumption, improve illumination performance and prolong working life.

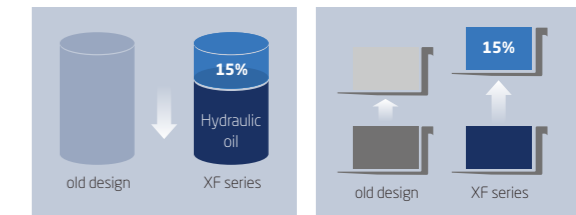

The new patent dynamic load sensing hydraulic steering system contributes to reduce loss of hydraulic, improve energy consumption and increase 15% lifting speed.



# Reliability

By focusing on enhancing reliability, reducing downtime, the XF series is able to make the greater productivity for customer.

The patent plated-fin type aluminum radiator is applied, the heat exchanging is approved, and improves the capability for operation in severe environments.



There're four levels shock absorption applied to reduced the vibration from the road to the driver. The damping pad is applied reduce the vibration, Like between the steering axle and the chassis, The engine, torque convertor and the chassis, the overhead guard and the chassis. And the suspension seat is another vibration reduction.

High strength chassis, mast and front/rear axle are to make sure the reliability of the truck, even for high strength application.

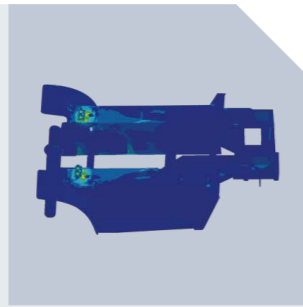

All the controllers, relays, and safety fuses are allocated in the controller box, free to water and dust. The main electronic components are waterproof, which is capable operator in severe environment.



# Easy Maintenance



Careful design facilitates inspection and servicing. Easy maintenance reduces the amount of downtime and helps to reduce cost also.

The location of the air-filter is easy to reach, and it's very easy to replace the filter.

Brake drum is installed outside of wheel hub, easy to remove and install when we replace the brake shoes.

All the locations of the engine oil level dipstick, filter of hydraulic, water separator are easy to reach, and very easy for engineer to check.

There's gas spring support for the front cover of radiator, and it can auto-open when the rear cover of radiator is opened.



The new stamped air cleaner featuring tangential intake, double seal with safety filter is durable, corrosion-free and vibration-resistant, provides better filter efficiency and lower intake resistance than the previous.



The battery is located above the fuel tank, there's battery box and adiabatic plate between them to prolong the battery's working life.



Add return oil filter of gearbox and multi-valve, improving the cleanliness of transmission and hydraulic oil.

# Safety

A wide range of technologies are applied to ensure absolute safety for both the operator and those in the surrounding. Independent braking and steering circuit without interference.



There's an energy accumulator applied in the braking system, which means when the engine is shut down, it can also provide more than 4 times emergency brake.



The locking device of the engine hood damper and parking brake help add to safety.



1. The seat sensor system incorporates lifting/tilting and traveling locking function. When the operator leaves the seat, the system automatically locks lifting/tilting and disables traveling to ensure safety.
2. A throttling device is adopted to avoid the mast being out of control even some pipes are broken.

# Standards



Transmission	Steering	Chassiss	Control	Hydraulic
/ Suspension transmission / Oil filter / Dipstick / Oil cooler / Non-asbesttos bake / Drum brake / Wet brake (W75/W96)	/ Full hydraulic power steering / Smaller diameter steering wheel / Adjuster of steering wheel / Shock absorber of steering axle	/ Skidproof pedal / Rubber pedal / Engine hood spring	/ Power steering / Suspension pedal / Integrated combination switch / Parking brake	/ Dynamic load sending control valve / Hydraulic oil filter / Tilt cylinder self-lock valve / Hydraulic oil dipstick / Accumulator / Hydraulic oil radiator

Truck	Power	Electronics	Mast
/ Traction device / Hand grip / Standard seat / Floating overhead guard / Waterproof cover on the guard / Back view mirror / Pneumatic tyres	/ Big capacity aluminum radiator / Whirlwind air cleaner / Safety filter / High-efficient intake muffler / High-efficient exhaust muffler	/ High-efficient front lights / High-efficient LED rear lights / Service-free start battery / Combination controller / LCD display / Neutual switch / Hour meter / Fuel gauge / Water temperature gauge	/ Pre-heat indicator / Charging indicator / Engine fuel pressure warning / Oil temperature / Horn / Reversing buzzer / Air-filter with jam sensor / Emergency power off

# Options

Truck	Transmission	Power	Hydraulic	Electronics	Mast
/ Floating cabin / Cabin heater / Front window / Super elastic tyre / Non-mark tyre(white/green) / Suspension seat / Extinguisher / Special given color / Boot for tilt cylinder / Counter weight net / Seat sensor system / Hood lock (for W96 engine) / Toolbox	/ Wet brake	/ Upright exhaust system / Air pre-cleaner / Net cover of radiator / Spark arrester / Purified exhaust system / Fan protector	/ Auxiliary hydraulic valve / Electro-hydraulic / Proportional control system	/ OBD / Front working light / Rear working light / Warning lamp	/ Duplex wide view free-lift mast / Triplex wide view free-lift mast / Special forks / Wider fork carriage / Widerload back rest

# Optional Attachments

- / Paper roll clamp
- / Rotating bale clamp
- / Load stabilizer
- / Multi-drum clamp
- / Bale clamp
- / Drum clamp
- / Dumping clamp
- / Crane arm
- / String Pole
- / Sideshifter
- / Rotating forks
- / Fork extensioner
- / Load release device
- / Carton clamp
- / Push-pull device
- / Bucket
- / Hook
- / Lengthened fork



# 8.0~10t XF series mast: (pneumatic)

Type	Model	Max.fork height	Overall height		Free lift Without backrest	Load distance, centre of drive axle to fork	Titl range	Load capacity	
			Lowered	Extended Without backrest				Load capacity at 600mm Double tire	
								8t	10t
Wide view Duplex mast	X80M250	2500	2450	3710	200	714	6/12	8000	/
	X80M270	2700	2550	3910	200	714	6/12	8000	/
	X80M300	3000	2700	4210	200	714	6/12	8000	/
	X80M330	3300	2850	4510	200	714	6/12	8000	/
	X80M350	3500	2950	4710	200	714	6/12	8000	/
	X80M360	3600	3000	4810	200	714	6/12	8000	/
	X80M400	4000	3200	5210	200	714	6/12	8000	/
	X80M430	4300	3400	5510	200	714	6/6	8000	/
	X80M450	4500	3500	5710	200	714	6/6	8000	/
	X80M480	4800	3650	6010	200	714	6/6	8000	/
	X80M500	5000	3750	6210	200	714	6/6	8000	/
	X80M550	5500	4050	6740	200	714	3/6	7400	/
	X80M600	6000	4300	7240	200	714	3/6	7000	/
	X80M650	6500	4600	7790	200	714	3/6	5800	/
	X100M250	2500	2600	4055	200	726	6/12	/	10000
	X100M270	2700	2700	4255	200	726	6/12	/	10000
	X100M300	3000	2850	4555	200	726	6/12	/	10000
	X100M330	3300	3000	4855	200	726	6/12	/	10000
	X100M350	3500	3100	5055	200	726	6/12	/	10000
	X100M360	3600	3150	5155	200	726	6/12	/	10000
X100M400	4000	3350	5555	200	726	6/12	/	10000	
X100M430	4300	3550	5855	200	726	6/6	/	10000	
X100M450	4500	3650	6055	200	726	6/6	/	10000	
X100M480	4800	3800	6355	200	726	6/6	/	10000	
X100M500	5000	3900	6555	200	726	6/6	/	10000	
X100M550	5500	4200	7055	200	726	3/6	/	9000	
X100M600	6000	4450	7555	200	726	3/6	/	8000	
X100M650	6500	4750	8055	200	726	3/6	/	6700	
Full free duplex mast	X80U230	2300	2350	3505	1145	719	6/12	8000	/
	X80U250	2500	2450	3705	1245	719	6/12	8000	/
	X80U270	2700	2550	3905	1345	719	6/12	8000	/
	X80U300	3000	2700	4205	1495	719	6/12	8000	/
	X80U330	3300	2850	4505	1645	719	6/12	8000	/
	X80U360	3600	3000	4805	1795	719	6/12	8000	/
	X80U400	4000	3200	5205	1995	719	6/12	8000	/
	X100U230	2300	2500	3845	955	744	6/12	/	10000
	X100U250	2500	2600	4045	1055	744	6/12	/	10000
	X100U270	2700	2700	4245	1155	744	6/12	/	10000
	X100U300	3000	2850	4545	1305	744	6/12	/	10000
	X100U330	3300	3000	4845	1455	744	6/12	/	10000
	X100U360	3600	3150	5145	1605	744	6/12	/	10000
	X100U400	4000	3350	5545	1805	744	6/12	/	10000
	Full free triplex mast	X80N450	4500	2750	5775	1485	759	6/6	7000
X80N480		4800	2850	6075	1585	759	6/6	7000	/
X80N500		5000	2950	6360	1600	759	6/6	6500	/
X80N550		5500	3100	6810	1800	759	3/6	6100	/
X80N600		6000	3250	7275	1985	759	3/6	5600	/
X80N650		6500	3530	7840	2200	759	3/6	5000	/
X80N700		7000	3700	8310	2400	759	3/6	4200	/
X100N450		4500	2850	6055	1305	794	6/6	/	8500
X100N480		4800	2950	6355	1405	794	6/6	/	8500
X100N500		5000	3050	6555	1505	794	6/6	/	8200
X100N550		5500	3200	7055	1655	794	3/6	/	7700
X100N600		6000	3350	7555	1805	794	3/6	/	7000
X100N650		6500	3630	8055	2085	794	3/6	/	6200
X100N700		7000	3800	8555	2255	794	3/6	/	5200

With sideshifter minus 500kg,with integral sideshifter minus 400kg.

# 12t XF series mast: (pneumatic)

Type	Model	Max.fork height	Overall height		Free lift Without backrest	Front overhang	Titl range	Capacity		
			Lowered	Extended Without backrest				Load capacity 600mm Double tire		
								12t	kg	
Wide view mast	XX120M270	2700	2850	4405	200	739	6/12	12000		
	XX120M300	3000	3000	4705	200	739	6/12	12000		
	XX120M330	3300	3150	5005	200	739	6/12	12000		
	XX120M360	3600	3300	5305	200	739	6/12	12000		
	XX120M400	4000	3550	5705	200	739	6/12	12000		
	XX120M430	4300	3700	6005	200	739	6/6	12000		
	XX120M450	4500	3800	6205	200	739	6/6	12000		
	XX120M480	4800	3950	6505	200	739	6/6	12000		
	XX120M500	5000	4050	6705	200	739	6/6	12000		
	XX120M550	5500	4350	7205	200	739	3/6	10500		
	XX120M600	6000	4600	7705	200	739	3/6	9000		
	XX120M650	6500	4900	8205	200	739	3/6	7500		
	Full free triplex mast	XX120N450	4500	3000	6205	1305	807	6/6	10200	
		XX120N480	4800	3100	6505	1405	807	6/6	10200	
		XX120N500	5000	3200	6705	1505	807	6/6	9800	
XX120N550		5500	3350	7205	1655	807	3/6	9200		
XX120N600		6000	3500	7705	1805	807	3/6	8000		
XX120N650	6500	3780	8205	2085	807	3/6	7000			



